

TIMKEN®

Torrington® Fafnir®



Mounting Guide



Mounting Guide

TABLE OF CONTENTS

	PAGE
Product Information	2-7
Wide Inner Ring bearings	2-3
Housed Units	4-5
Spherical Roller bearings	6-7
Internal Clearances	8-12
Installation of Drawn Cup bearings	13
How to Inspect a bearing journal or housing bore	14-16
Shaft and Housing Fits	17-39
Shaft Design – Needle bearings	40
Housing Design – Needle bearings	41
Shaft and Housing Shoulders	42-44
Tables	45-46
Torrington Shaft Mounting Accessories	47

INTRODUCTION

The intent of this mounting guide is to provide the information you need to properly mount Timken® Torrington® ball, roller and needle bearings. For additional assistance please feel free to contact a Timken Authorized Distributor or sales office in your area. For your nearest Timken sales representative, call (800) 223-1954. Outside the U.S. and Canada, call (330) 438-3000.

The Timken® Fafnir® line from The Timken Company originated the wide inner ring bearing design for ball bearings which could be easily mounted on straight shafts and positioned without shoulders, locknuts or adapters.

The internal bearing construction is basically the same as the deep race, single row radial type with ability to carry radial, thrust and combined loads, while providing low friction qualities which are characteristic of high-grade bearings. The inner ring is generally extended on both sides of the race to provide additional shaft support, and is locked to the shaft by specially designed setscrews or by the Timken-originated, eccentric self-locking collar or concentric collar. The wide inner ring bearings are also available with cylindrical or spherical outside diameters. The cylindrical or straight O.D. type is used for mounting in straight-bored housings. The spherical O.D. type must be mounted in a corresponding spherical seat and is used to compensate for shaft or housing misalignments.

FAFNIR WIDE INNER RING BEARINGS WITH LOCKING COLLARS

The following series are available with the cam (self-locking) collar.

RR Series

These bearings feature the flareout, contact type R-seal which encloses a synthetic rubber impregnated washer between two metal caps. Most sizes incorporate the Fafnir Shroud-Seal design. R-seal wide inner ring bearings are available in the following non-relubricatable variations: KR (one seal, cylindrical O.D.), KRR and KRRB (two seals). Relubricatable versions are: G-KRR, G-KRRB and GN-KRRB (heavy-duty).

RA-RR Series

The RA-RR series features an extended inner ring and self-locking collar for simple effective shaft retention in a standard series bearing. The newly developed, positive contact, land-riding R-seal provides improved protection against the heavy contamination encountered in many applications. All sizes have a heat stabilized, moisture conditioned 6/6 nylon retainer which has proven extremely effective under conditions of misalignment.

RA-RR extended inner ring bearings are available as RA-RR (two-seals, straight O.D.) and RA-RRB (two seals, spherical O.D.). Relubricatable versions are GRA-RR and GRA-RRB.

Tri-Ply-Seal Series

Tri-Ply Seal bearings are designed for environments where severe conditions and moisture are present. The new one piece Tri-Ply seals incorporate a highly effective seal design molded to an exterior shroud cap. The shroud cap protects the seal lips from fiber wrap and abrasion while enhancing the overall sealing effectiveness of the unit. All units incorporate the self-locking collar and have a nylon retainer. Tri-ply Seal bearings are available in both a non-relubricatable (KPPB) and relubricatable version (G- KPPB).

External Self-Aligning Series

The construction of this series permits the inner assembly, which contains an open type ball bearing with spherical O.D. to align in the seat of the mating outer ring. The seat of this outer ring is matched with the spherical O.D. of the ball bearing outer ring providing unrestricted self-alignment which allows the inner assembly to become square and true with the shaft. Self-aligning units are available in both standard SM-S or heavy SMN-S series.

RA-DD Series Bearings

The new RA-DD series bearings are extended inner ring type with cam locking collars. They incorporate two close fitting non-contact grease shields to effectively retain lubricant and provide protection against harmful contaminants. The non-contact metallic shields provide improved high speed and low torque performance such as required for high speed printing press applications. The 6/6 molded nylon retainer has proven extremely effective under conditions of misalignment. These bearings are dimensionally interchangeable and have the same load capacities as the RA-RR series. (Available in $\frac{5}{8}$ "-1 $\frac{1}{2}$ " shaft sizes.)

WIDE INNER RING BEARINGS WITH SETSCREW LOCKING DEVICE

The following series are available with the setscrew locking device with special setscrews that are resistant to loosening during operation.

YA-RR series

The (G)YA-RR(B)series relubricatable and non-relubricatable bearings are an extended inner ring type with specially designed setscrews. Positive contact land-riding R-Seals provide protection against harmful contaminants and retain lubricant.

Setscrew Series bearings are available in both non-relubricatable version YA-RRB and relubricatable version GYA-RRB. Both types have nylon retainers.

ER Series

This series offers industry standard mounting dimensions and standard nomenclature for a large variety of sizes of relubricatable, extended inner ring bearings for through-bored housings. All bearings in this series have nylon retainers and are equipped with snap rings which eliminate the need for machining housing shoulders.

Positive contact landriding R Seals provide protection against harmful contaminants and retain lubricant. ER bearings are all black oxide coated for corrosion resistance.



RR Series



RA-RR Series



Tri-Ply-Seal Series



External Self-Aligning Series



RA-DD Series



YA-RR Series



ER Series

FAFNIR WIDE INNER RING BEARINGS WITH CONCENTRIC COLLARS

GC-KRRB Series

The GC-KRRB wide inner ring bearings are relubricatable with spherical outside diameters, nylon retainers and shroud seals. The metal shroud maintains tight seal contact against the inner ring and shields the rubber seals from damage due to dirt or fiber wrap. The concentric collar is locked to the shaft by two setscrews, located 120° apart, which are mated with threaded holes in the collar and drilled holes in the bearing inner ring.



GC-KRRB Series

CAM (SELF-LOCKING) COLLAR

	<p>1. Observe cam design of the wide inner ring and self locking collar.</p>
	<p>2. Mate the cam of the collar with the cam of the wide inner ring.</p>
	<p>3. Press the locking collar against the wide inner ring and turn in the direction of shaft rotation until tightly engaged.</p>
	<p>4. With drift pin in collar hole, strike in direction of shaft rotation to lock.</p> <p>For Stationary shafts and outer ring rotation, turn collar in opposite direction of rotation.</p>
	<p>5. Tighten setscrew in collar.</p> <p>CONCENTRIC COLLAR For simplified installation, the concentric collar is normally assembled to the wide inner ring for shipment. Slip the complete unit on the shaft and tighten both setscrews.</p>

Ball Bearing housed units, originated by Timken's own Fafnir line, are available in a wide variety of types and sizes to accommodate a complete range of operating conditions.

These units generally have cast iron housings and are designed for mounting on straight shafts with a slip fit. The self-locking collar and the setscrew inner bearing designs provide ease in mounting, bolt holes in housings take standard bolts for assembling these units to machinery frames. Several series are also available with the concentric locking collar.

As most of these units are made with a self-aligning feature, it is

unnecessary for the user to refine his design in excess of practical limits. If desired, units incorporating prelubricated wide inner ring bearings may be furnished without grease fittings.

There are several basic types of housed units available: Pillow Blocks, Flanged Cartridges, Flangette Units, Cylindrical Cartridges and Take-up Units. The type required is generally determined by its application and mounting requirements. Within the basic type selected, numerous variations allow for load factors, shaft sizes, mounting surface dimensions, base to shaft center line heights and lubrication requirements.

PILLOW BLOCKS

Pillow blocks, the most commonly used type of mounted units, are designed to provide shaft support where the mounting surface is parallel to the shaft axis. The bolt holes are usually slotted for adjustment during mounting.

Pillow blocks are supplied in both standard and heavy duty series. Pressed steel and rubber pillow blocks are also available for light duty applications.



FLANGED CARTRIDGES

Flanged cartridges are used where a shaft passes through the machine frame at a right angle. A four bolt mounting is the most common, however, where the mounting area is restricted, three and two bolt versions are available. A piloted flanged cartridge, also available, provides additional mounting accuracy and support.

Flanged cartridges are supplied in both standard and heavy duty series. Iron and rubber flanged cartridges are also available.

A complete line of Flangette Units, pressed steel flanged cartridges, provides an economical solution to light duty applications. Two, three and four bolt mountings are available along with a relubricable version.



CYLINDRICAL CARTRIDGES

Cylindrical cartridges, like flanged cartridges, provide shaft support where the shaft axis is perpendicular to and passing through a machined housing which is generally very thick. The outside diameter of the cylindrical cartridges permits mounting with a press fit into a straight, through-bored housing.

Cylindrical cartridges have a machined spherical bearing seat to provide initial shaft alignment in standard duty applications. Synthetic, conductive rubber cylindrical cartridges are also available for applications where low cost, light duty, low noise operation is essential.



TAKE-UP UNITS

Take-up units are used where shaft adjustment and belt tightening devices are required, such as conveyor applications. Frames for take-up units provide for either side or top mounting.

Take-up units are available in cast iron for standard duty and pressed steel for economical, light duty applications.







FAFNIR SELF-LOCKING COLLAR INSTALLATION

Most Timken Fafnir housed units come equipped with the self-locking collar to facilitate the mounting of wide inner ring bearings. This self-locking collar eliminates the need for locknuts, washers, shoulders, sleeves, and adapters.

The locking collar has a counterbored recess which is made purposely eccentric to the bore. The collar recess and the end of the

bearing inner ring with which it engages are both machined so that they act as mating cams when on the shaft.

When the collar is engaged to the inner ring, it grips the shaft tightly with a positive binding action that increases with use. No adjustments of any kind are necessary.

	<p>1. Slip the shaft through the pillow block or other Fafnir housed unit which incorporates the wide inner ring bearing. Be certain the bearing is aligned in position along the shaft to eliminate any possibility of cramping loads.</p>
	<p>2. Fasten the unit securely to the base using the proper bolt size.</p>
	<p>3. Place the self-locking collar on the shaft with its cam adjacent to the cam on the end of the bearing's inner ring. Turn the collar in the direction of shaft rotation. The eccentric recessed cam will slide over and engage the corresponding cam on the bearing inner ring.</p>
	<p>4. Using a lightweight hammer and a drift pin inserted in the drift pin hole strike in the direction of shaft rotation to positively engage the collar. The wide inner ring is now locked to the shaft.</p>
	<p>5. As a final step, fully tighten the setscrew. It exerts a wedging action to hold the collar always in the engaged position, even under shock load. This Fafnir design will operate effectively after the cams are tightly locked in most cases with no setscrews at all.</p>

FAFNIR SETSCREW LOCKING BEARING

Steps 1 and 2 can be repeated from the Self Locking Collar Installation above. To lock the setscrew bearing, simply tighten each inner ring setscrew to the recommended torque listed by shaft size. See chart below.

It may be necessary to rotate the shaft to provide an easy access of the setscrew wrench to the setscrews. To disassemble, loosen the setscrews.

Shaft Size	in/mm	Recommended	
		Torque in lbs.	(n • m)
1/2-11/16	17 mm	35 in lbs	4 (n • m)
3/4-1	20-25 mm	80 in lbs	9 (n • m)
1 1/16-1 3/4	30-45 mm	155 in lbs	18 (n • m)
1 13/16-2 3/16	50-55 mm	275 in lbs	31 (n • m)

CONCENTRIC COLLAR

For simplified installation of Fafnir housed units equipped with concentric collar bearings, the collar is normally assembled to the wide inner ring for shipment. Slip the complete unit on the shaft following steps 1 and 2 described for the self-locking collar procedure, and tighten both setscrews.

MOUNTING PROCEDURES – TORRINGTON SPHERICAL ROLLER BEARINGS

Depending on the size of bearing and the application, there are different methods for mounting rolling bearings. In all methods, however, certain basic rules must be observed.

Cleanliness

Choose a clean environment. Work in an atmosphere free from dust or moisture. If this is not obtainable, and sometimes in the field it isn't, the installer should make every effort to insure cleanliness by use of protective screens, clean clothes, etc.

Plan the work

Know in advance what you are going to do and have all necessary tools at hand. This reduces the amount of time for the job and lessens the chance for dirt to get into the bearing.

Inspection and preparation

All component parts of the machine should be on hand and thoroughly cleaned before proceeding. Housings should be cleaned, including blowing out the oil holes. **Do not use an air hose on bearings.** If blind holes are used, insert a magnetic rod to remove metal chips that might have become lodged there during fabrication.

Shaft shoulders and spacer rings contacting the bearing should be square with the shaft axis. The shaft fillet must be small enough to clear the radius of the bearing.

On original installations, all component parts should be checked against the detail specification prints for dimensional accuracy. Shaft and housing should be carefully checked for size and roundness.

Shaft and housing finish

Shaft surfaces on which the bearing will be mounted must be clean and free from nicks or burrs. For an application with stationary housing and rotating shaft, it is suggested the bearing seat on the shaft be ground to 63 RMS maximum. If it is impractical to use a ground finish, a machined finish of 125 RMS is acceptable in many cases, but the amount of interference fit should be slightly increased. Consult our Engineering Department for recommendations.

For a stationary outer ring which is required to float (i.e. slide axially in the housing), a housing surface finish of 63 RMS maximum is suggested. Where the outer ring is not required to float, a surface finish of 125 RMS maximum is generally satisfactory.

DON'T REMOVE THE BEARING FROM ITS WRAPPER UNTIL ACTUALLY READY TO MOUNT IT.

MOUNTING STRAIGHT BORE BEARINGS

Heat expansion method

Most applications require a tight interference fit on the shaft. Mounting is simplified by heating the bearing to expand it sufficiently to slide easily onto the shaft. Two methods of heating are in common use:

1. Tank of heated oil.
2. Induction heating.

The first is accomplished by heating the bearing in a tank of oil having a **high flash** point. The oil temperature should not be allowed to exceed 250° F. A temperature of 200°F is sufficient for most applications. The bearing should be heated at this temperature, generally for 20 or 30 minutes, until it is expanded sufficiently to slide onto the shaft very easily.

The induction heating method is particularly suited for mounting small bearings in production line assembly. Induction heating is rapid, and care must be taken to prevent bearing temperature from exceeding 200° F. Trial runs with the unit and bearing are usually necessary to obtain the proper timing. Thermal crayons (such as Tempilstics*) which melt at predetermined temperatures can be used to check the bearing temperature.

While the bearing is still hot, it should be positioned squarely against the shoulder. Lockwashers and locknuts, or clamping plates, are then installed to hold the bearing against the shoulder of the shaft. As the bearing cools, the locknut or clamping plate should be tightened. In cases of outer ring rotation,

where the outer ring is a tight fit in the housing, the housing member can be expanded by heating.

The oil bath is shown in Figure 1. The bearing should not be in direct contact with the heat source. The usual arrangement is to have a screen several inches off the bottom of the tank. Small support blocks separate the bearing from the screen. It is important to keep the bearing away from any localized high-heat source that may raise its temperature excessively, resulting in race hardness reduction.

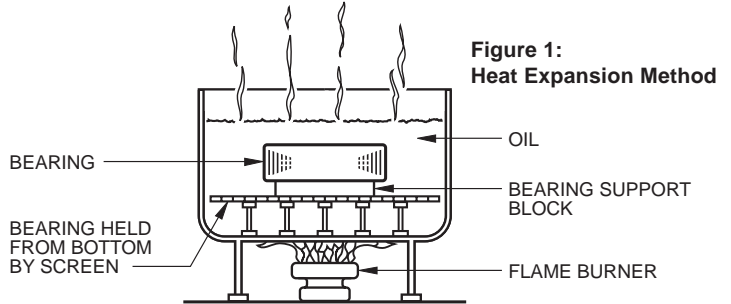

Flame-type burners are commonly used. An automatic device for temperature control is desirable. If safety regulations prevent the use of an open heated oil bath, a mixture of 15% soluble-oil in water may be used. This mixture may be heated to a maximum temperature of about 200° F., without being flammable. The bath should be checked from time to time to insure its proper composition as the water evaporates. The bath leaves a thin film of oil on the bearing sufficient for temporary rust prevention, but normal lubrication should be supplied to the bearing as soon as possible after installation. Be sure all of the soluble-oil in water solution has been drained away from the bearing.

Arbor press method

The alternative method of mounting, generally used only on smaller sizes, is to press the bearing onto the shaft or into the housing. This can be done by using an arbor press and a mounting tube as shown in Figure 2. The tube can be of soft steel with inside diameter slightly larger than the shaft. The O.D. of the tube should not exceed the maximum shoulder height. The tube should be faced square at both ends, thoroughly clean inside and out, and long enough to clear the end of the shaft after the bearing is mounted.

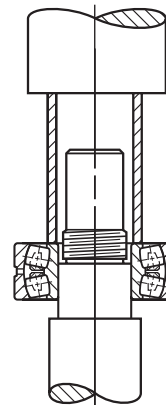

Figure 2:
Arbor Press Method

If the outer ring is being pressed into the housing, the O.D. of the mounting tube should be slightly smaller than the housing bore, and the I.D. should not be less than the recommended housing shoulder diameter in the tables of dimensions.

Coat the shaft with light machine oil to reduce the force needed for the press fit. Carefully place the bearing on the shaft making sure it is square with the shaft axis. Apply steady pressure from the arbor ram to drive the bearing firmly against the shoulder.

Never attempt to make a press fit on a shaft by applying pressure to the outer ring, or a press fit in a housing by applying pressure to the inner ring.

* Registered Trademark, Tempil Corp.

SHAFT MOUNTING TORRINGTON TAPERED BORE SPHERICAL ROLLER BEARINGS

Although the fit of a tapered bore spherical roller bearing can be determined by measuring the distance the bearing is forced onto the tapered seat, it is more practical to measure the **reduction of radial internal clearance** caused by expansion of the inner ring. This procedure requires determining the **initial RIC** before mounting, and checking the RIC during mounting until the proper **reduction of RIC** has been accomplished.

To determine initial RIC, the following procedure should be observed. A feeler gauge with the thinnest blade of 0.0015" is used. Place the bearing in an upright position with inner and outer ring faces parallel. Place thumbs on the inner ring bore and oscillate inner ring two or three times, pressing down firmly. This "seats" the inner ring and rolling elements. Position the individual roller assemblies so that a roller is at the top of the inner ring – on both sides of the bearing. Press the two top rollers inward to assure proper contact with the inner ring raceways. With the rollers in correct position, insert a thin blade of the feeler gauge between the rollers. Move it carefully over the top



roller, between the roller and outer ring raceway. Repeat this procedure, using thicker feeler gauge blades, until one is found that will not go through. The blade thickness that preceded the "no-go" blade is a measure of radial internal clearance (RIC) before installation.

Determine the target value of the **reduction of RIC** following procedure outlined in the example following. Start the mounting procedure by lubricating the tapered shaft with a light coat of machine oil. Slide the bearing onto the shaft as far as it will go. As the locknut is tightened, the interference fit builds up resulting in expansion of the inner ring. Periodically measure the RIC to keep track of the **reduction in RIC**.



Continue the procedure until the proper amount of reduction is obtained do not exceed recommended amount of reduction. As a final check, make sure that the remaining RIC equals or exceeds the **minimum mounted** clearance shown on page 10.

During mounting, the RIC should be checked at the unloaded roller. If this happens to be at the bottom, make sure that the roller is raised to seat firmly on the inboard portion of the inner race.

MOUNTING

Adapters vs. Straight Bore

Usually a spherical roller bearing Pillow block assembly is mounted to a straight shaft using a tapered bore bearing and adapter assembly. Standard commercial shafting can be used without additional machining. (Recommended shaft diameters are shown on page 18-21).

Adapter mount also permits maximum flexibility in the axial positioning of the bearing on the shaft and will accommodate light locational thrust loads. Timken® Torrington® pillow blocks for tapered bore and adapter-mounted bearings are available in Series 225, 226, 230, 231K and 232K.

Adapter mounted spherical roller bearings require the correct removal of diametral clearance from the bearing to prevent relative rotation between inner race and sleeve or shaft. Failure to employ proper mounting procedures can cause heating and reduced bearing performance.

When application conditions produce heavy thrust loads or a need exists for exact axial location or a positive shaft interference fit, a direct straight bore mounting may be the best option. This requires a shouldered shaft, machined for proper fit and a straight bore bearing. Torrington pillow block assemblies for straight bore applications are available in Series 222, 223, 231, and 232.

Recommended fits for shafts in cylindrical bore spherical roller bearings are shown on pages 17 through 25. For applications involving heavy shock, vibration, unbalanced rotating loads or other abnormal conditions, consult your Timken sales associate.

Fixed and Float Pillow Blocks

Any style of Torrington pillow blocks can be easily installed either at the float or fixed position on the shaft. For the fixed position, a stabilizing ring is added between the bearing outer ring face and the housing shoulder to positively locate the shaft and prevent axial movement.

Some applications require centering of the bearing in its housing. To accomplish this, two special width stabilizing rings can be ordered.

In the float position, the ring is not used allowing the bearing to move axially (a maximum of 3/8") to compensate for thermal expansion or contraction of the shaft.

Pillow blocks ordered by the numbers in the dimensional tables are fixed units. To order float units specify by adding suffix "Float" or "FL" to the pillow block number.

Closed End Installations

In some applications, the shaft end is designed to terminate inside the pillow block. For such a design, positive fitting end-closure inserts are available to seal out contaminants and retain lubricants. Torrington heavy-duty end plugs include O-rings for positive sealing.

Designers and installers need to make sure the shaft end does not contact the closure. A minimum of 1/8" clearance at maximum thermal expansion is recommended between the end of the shaft and the closure. Dimension "Y" in the product catalog tables defines the maximum permissible length of the shaft from center line of the pillow block housing. If end closure is desired, specify by adding "CL" (one end closed) to the pillow block assembly number.

FAFNIR RADIAL BALL BEARINGS

In the manufacture of ball bearings, it is standard practice to assemble rings and balls with a specified internal clearance. This characteristic is necessary to absorb the effect of press fitting the bearing rings at mounting.

Internal clearances sometimes are utilized to compensate for thermal expansion of bearings, shafts and housings or to provide a contact angle in the bearing after mounting.

Internal clearance can be measured either by gauging radially or axially.

Radial measurement is accepted as the more significant characteristic because it is more directly related to shaft and housing fits. It also is the method prescribed by the American Bearing Manufacturers Association (ABMA).

Radial Internal Clearance

The radial internal clearance of a radial contact ball bearing can be defined as the average outer ring raceway diameter minus the average inner ring raceway diameter minus twice the ball diameter.

Radial internal clearance can be measured mechanically by moving the outer ring horizontally as pictured in Figure 1. The total movement of the outer ring when the balls are properly seated in the raceways determines the radial internal clearance. Several readings should be taken using different circumferential orientations of the rings in order to get a comprehensive average reading.

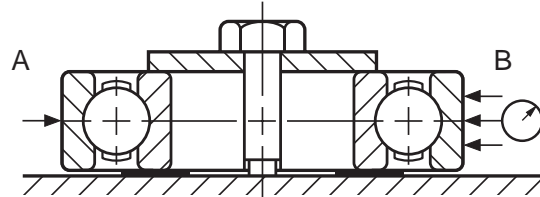

Figure 1

LIMITS FOR RADIAL INTERNAL CLEARANCE OF SINGLE ROW, RADIAL CONTACT BALL BEARINGS UNDER NO LOAD

(Applies to Bearings of ABEC-1, ABEC-3, ABEC-5, ABEC-7, and ABEC-9 Tolerances)

Tolerance Limits in ten-thousandths inches (.0001") and micrometers (µm)

Basic Bore Diameter MM		H (2)		R (0)		P (3)		J (4)		JJ (5)	
		Acceptance Limits		Acceptance Limits		Acceptance Limits		Acceptance Limits		Acceptance Limits	
Over	Incl.	low	high	low	high	low	high	low	high	low	high
2.5	10	0	3	1	5	3	9	6	11	8	15
		0	7	2	13	8	23	14	29	20	37
		0	3.5	1	7	4	10	7	13	10	18
10	18	0	9	3	18	11	25	18	33	25	45
		0	4	2	8	5	11	8	14	11	19
		0	10	5	20	13	28	20	36	28	48
24	30	0.5	4.5	2	8	5	11	9	16	12	21
		1	11	5	20	13	28	23	41	30	53
		0.5	4.5	2	8	6	13	11	18	16	25
30	40	1	11	6	20	15	33	28	46	40	64
		0.5	4.5	2.5	9	7	14	12	20	18	29
		1	11	6	23	18	36	30	51	45	73
50	65	0.5	6	3.5	11	9	17	15	24	22	35
		1	15	8	28	23	43	38	61	55	90
		0.5	6	4	12	10	20	18	28	26	41
65	80	1	15	10	30	25	51	46	71	65	105
		0.5	7	4.5	14	12	23	21	33	30	47
		1	18	12	36	30	58	53	84	75	120
80	100	1	8	6	16	14	26	24	38	35	55
		2	20	15	41	36	66	61	97	90	140
		1	9	7	19	16	32	28	45	41	63
120	140	2	23	18	48	41	81	71	114	105	160
		1	9	7	21	18	36	32	51	47	71
		2	23	18	53	46	91	81	130	120	180
140	160	1	10	8	24	21	40	36	58	53	79
		2	25	20	61	53	102	91	147	135	200
		1	12	10	28	25	46	42	64	59	91
160	180	2	30	25	71	63	117	107	163	150	230
		1	14	12	32	29	54	50	76	72	105
		3	36	30	81	74	137	127	193	183	267
200	240	1	14	12	32	29	54	50	76	72	105
		3	36	30	81	74	137	127	193	183	267
		1	14	12	32	29	54	50	76	72	105

Continued on the next page

LIMITS FOR RADIAL INTERNAL CLEARANCE OF SINGLE ROW, RADIAL CONTACT BALL BEARINGS UNDER NO LOAD

(Applies to Bearings of ABEC-1, ABEC-3, ABEC-5, ABEC-7, and ABEC-9 Tolerances)

Tolerance Limits in ten-thousandths inches (.0001") and micrometers (µm)

Basic Bore Diameter MM		H (2)		R (0)		P (3)		J (4)		JJ (5)	
		Acceptance Limits		Acceptance Limits		Acceptance Limits		Acceptance Limits		Acceptance Limits	
Over	Incl.	low	high	low	high	low	high	low	high	low	high
240	280	1	16	13	38	34	62	58	88	84	122
		3	41	33	97	86	157	147	224	213	310
280	320	2	19	16	45	41	71	67	101	97	139
		5	48	41	114	104	180	170	257	246	353
320	370	2	21	18	50	46	82	78	116	112	161
		5	53	46	127	117	208	198	295	284	409
370	430	3	25	22	58	54	95	91	134	130	187
		8	64	56	147	137	241	231	340	330	475
430	500	4	29	26	67	63	110	106	156	152	217
		10	74	66	170	160	279	269	396	386	551
500	570	4	32	29	76	72	125	121	177	173	248
		10	81	74	193	183	318	307	450	439	630
570	640	5	36	33	85	81	140	136	199	195	278
		13	91	85	216	206	356	345	505	495	706
640	710	8	45	42	94	90	155	151	222	218	307
		20	114	107	239	229	394	384	564	554	780
710	800	8	55	51	106	102	175	171	248	244	346
		20	140	130	269	259	445	434	630	620	879
800	1060	11	83	79	139	136	231	227	328	324	452
		28	211	201	353	345	587	577	833	823	1148

Fafnir radial clearance designations correlate with ABMA symbols as follows:

Fafnir Bearing Number Prefix	ABMA Symbol	Description
H	2	Snug fit; slight internal clearance; sometimes used to achieve a minimum of radial or axial play in an assembly. Example: H204K.
R	0	Medium fit; internal clearance generally satisfactory with recommended shaft and housing fits shown on pages 26-30. Example: RMM204K.
P	3	Loose fit; considerable internal clearance required for applications involving press fits on both inner and outer rings, extra interference fits, or temperature differentials. Example: P204K.
J	4	Extra Loose fit; large amount of internal clearance for applications involving large interference fits or temperature differentials. Example: J204K.
JJ	5	Extra-Extra Loose fit; extra large amount of internal clearance for applications with large temperature differential and interference fits on both rings.

End play

End play is an alternate method of measuring internal clearance and is rarely used except for certain special applications. End play is determined by mounting the bearing, as shown in Figure 2, with one of its rings clamped to prevent axial movement. A reversing measuring load is applied to the unclamped ring so that the resultant movement of that ring is parallel to the bearing axis. End play is the total movement of the unclamped ring when the load is applied first in one direction and then in the other.

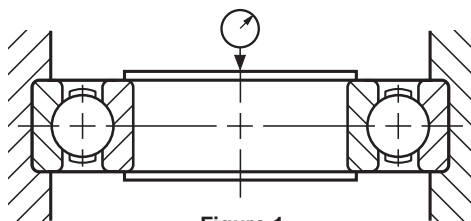

Figure 1

When the inner and outer ring raceway curvatures are accurately known, the free end play can readily be calculated from the values of no load radial clearance by the following formula:

$$E = \sqrt{4dR_D(K_O + K_i - 1) - R_D^2} \text{ or } \cong \sqrt{4dR_D(K_O + K_i - 1)}$$

(Where R_D^2 is generally a very small value and can be omitted for most calculations without introducing undue inaccuracy.)

E = Free end play where

K_O = outer race contour radius expressed as a decimal fraction of the ball diameter.

K_i = inner race contour radius expressed as a decimal fraction of the ball diameter

R_D = radial clearance (no load)

d = ball diameter

Contact Angle

The contact angle (α) is related to internal clearance as follows:

$$\alpha = \sin^{-1} \left(\frac{E}{2(K_O + K_i - 1)d} \right)$$

The contact angle (α) may also be accurately determined in a production bearing from its pitch diameter (P.D.) and by measuring the number of revolutions (N_c) of the ball and cage assembly relative to rotation (N_i) of the inner ring under a light thrust load.

$$(N_c) = .5N_i \left(1 - \frac{d}{P.D.} \cos \alpha \right)$$

$$\cos \alpha = \frac{P.D.}{d} \left(1 - \frac{N_c}{.5N_i} \right)$$

The accuracy of this method of measurement depends greatly upon the care taken in set-up. Balanced weight for thrust loading, vertical truing, slow turning, many turns, minimum lubricant of low viscosity and prerotation are all essential for instance. The races should not be radially restrained during the contact angle measurement.

TORRINGTON RADIAL SPHERICAL ROLLER BEARINGS

Radial Internal Clearance (RIC) is the radial play within a bearing. Torrington bearing RIC's allow a tight fit, with sufficient internal clearance after installation for normal operating conditions.

Spherical Roller Bearings with tapered bore (K) require a slightly greater interference fit on the shaft than would a cylindrical bore bearing. The effect of this greater interference fit is a reduction of RIC. For tapered bore bearings, it is critical to select the RIC that allows for this reduction.

For example, bearing number 22328K C3 (140 mm bore with C3 clearance) is to be mounted on a tapered shaft. By feeler gauging, RIC is found to be 0.007" (0.178mm). The chart indicates that the proper fit will be obtained when RIC is reduced by 0.0025" to 0.0035" (0.064 to 0.089 mm). Clearance after mounting is computed: 0.007"-

0.003"= 0.004" (0.178-0.076=0.102mm). The locknut should be tightened until RIC reaches 0.004" (0.102mm).

Several factors influence RIC reduction. Inner rings pressed into solid steel shafts expand approximately 80% of the interference fit. Outer rings pressed into steel or cast iron housings reduce RIC by about 60%, of the interference fit. For RIC reduction on hollow shafts or non-steel materials consult Timken sales engineers.

Torrington bearings are supplied with NORMAL RIC, unless otherwise specified. The desired RIC code must be added to the bearing number, FOLLOWING ALL OTHER SUFFIXES.

Min./max. values for each RIC are shown in the two adjacent columns directly beneath the selected RIC. For example, the minimum values shown for C5 are also the maximum values for C4; minimum values for C4 are also the maximum values for C3; etc.

RADIAL INTERNAL CLEARANCE LIMITS

All data on this page, except Bore I.D. are in inches/millimeters

Bore (nominal)		Cylindrical Bore						Tapered Bore						Recommended Reduction of RIC Due to Installation		Recommended RIC after Installation ⁽¹⁾
		Normal (Standard)		C4		C5	Normal (Standard)		C4		C5					
		min.	max.	min.	max.		min.	max.	min.	max.		min.	max.	min.	max.	
mm		min.	max.	min.	max.	min.	max.	min.	max.	min.	max.	min.	max.	min.	max.	min.
over	incl.	inch	inch	inch	inch	inch	inch	inch	inch	inch	inch	inch	inch	inch	inch	inch
		mm	mm	mm	mm	mm	mm	mm	mm	mm	mm	mm	mm	mm	mm	mm
24	30	0.0006 0.015	0.0010 0.025	0.0016 0.040	0.0022 0.055	0.0030 0.075	0.0037 0.095	0.0008 0.020	0.0012 0.030	0.0016 0.040	0.0022 0.055	0.0030 0.075	0.0037 0.095	0.0006 0.015	0.0008 0.020	0.0006 0.015
30	40	0.0006 0.015	0.0012 0.030	0.0018 0.045	0.0024 0.060	0.0031 0.080	0.0039 0.100	0.0010 0.025	0.0014 0.035	0.0020 0.050	0.0026 0.065	0.0033 0.085	0.0041 0.105	0.0008 0.020	0.0010 0.025	0.0006 0.015
40	50	0.0008 0.020	0.0014 0.035	0.0022 0.055	0.0030 0.075	0.0039 0.100	0.0049 0.125	0.0012 0.030	0.0018 0.045	0.0024 0.060	0.0031 0.080	0.0039 0.100	0.0051 0.130	0.0010 0.025	0.0012 0.030	0.0008 0.020
50	65	0.0008 0.020	0.0016 0.040	0.0026 0.065	0.0035 0.090	0.0047 0.120	0.0059 0.150	0.0016 0.040	0.0022 0.055	0.0030 0.075	0.0037 0.095	0.0047 0.120	0.0063 0.160	0.0012 0.030	0.0015 0.038	0.0010 0.025
65	80	0.0012 0.030	0.0020 0.050	0.0031 0.080	0.0043 0.110	0.0057 0.145	0.0071 0.180	0.0020 0.050	0.0028 0.070	0.0037 0.095	0.0047 0.120	0.0059 0.150	0.0079 0.200	0.0015 0.038	0.0020 0.051	0.0010 0.025
80	100	0.0014 0.035	0.0024 0.060	0.0039 0.100	0.0053 0.135	0.0071 0.180	0.0089 0.225	0.0022 0.055	0.0030 0.080	0.0043 0.110	0.0055 0.140	0.0071 0.180	0.0091 0.230	0.0018 0.046	0.0025 0.064	0.0014 0.036
100	120	0.0016 0.040	0.0030 0.075	0.0047 0.120	0.0063 0.160	0.0083 0.210	0.0102 0.260	0.0026 0.065	0.0039 0.100	0.0053 0.135	0.0067 0.170	0.0087 0.220	0.0110 0.280	0.0020 0.051	0.0028 0.071	0.0020 0.051
120	140	0.0020 0.050	0.0037 0.095	0.0057 0.145	0.0075 0.190	0.0094 0.240	0.0118 0.300	0.0031 0.080	0.0047 0.120	0.0063 0.160	0.0079 0.200	0.0102 0.260	0.0130 0.330	0.0025 0.064	0.0035 0.089	0.0022 0.056
140	160	0.0024 0.060	0.0043 0.110	0.0067 0.170	0.0087 0.220	0.0110 0.280	0.0138 0.350	0.0035 0.090	0.0051 0.130	0.0071 0.180	0.0091 0.230	0.0118 0.300	0.0150 0.380	0.0030 0.076	0.0040 0.102	0.0022 0.056
160	180	0.0026 0.065	0.0047 0.120	0.0071 0.180	0.0094 0.240	0.0122 0.310	0.0154 0.390	0.0039 0.100	0.0055 0.140	0.0079 0.200	0.0102 0.260	0.0134 0.340	0.0169 0.430	0.0030 0.076	0.0045 0.114	0.0024 0.061
180	200	0.0028 0.070	0.0051 0.130	0.0079 0.200	0.0102 0.260	0.0134 0.340	0.0169 0.430	0.0043 0.110	0.0063 0.160	0.0087 0.220	0.0114 0.290	0.0146 0.370	0.0185 0.470	0.0035 0.089	0.0050 0.127	0.0028 0.071
200	225	0.0031 0.080	0.0055 0.140	0.0087 0.220	0.0114 0.290	0.0150 0.380	0.0185 0.470	0.0047 0.120	0.0071 0.180	0.0098 0.250	0.0126 0.320	0.0161 0.410	0.0205 0.520	0.0040 0.102	0.0055 0.140	0.0030 0.076
225	250	0.0035 0.090	0.0059 0.150	0.0094 0.240	0.0126 0.320	0.0165 0.420	0.0205 0.520	0.0055 0.140	0.0079 0.200	0.0106 0.270	0.0138 0.350	0.0177 0.450	0.0224 0.570	0.0045 0.114	0.0060 0.152	0.0035 0.089
250	280	0.0039 0.100	0.0067 0.170	0.0102 0.260	0.0138 0.350	0.0181 0.460	0.0224 0.570	0.0059 0.150	0.0087 0.220	0.0118 0.300	0.0154 0.390	0.0193 0.490	0.0244 0.620	0.0045 0.114	0.0065 0.165	0.0040 0.102
280	315	0.0043 0.110	0.0075 0.190	0.0110 0.280	0.0146 0.370	0.0197 0.500	0.0248 0.630	0.0067 0.170	0.0094 0.240	0.0130 0.330	0.0169 0.430	0.0213 0.540	0.0268 0.680	0.0050 0.127	0.0070 0.178	0.0040 0.102
315	355	0.0047 0.120	0.0079 0.200	0.0122 0.310	0.0161 0.410	0.0217 0.550	0.0272 0.690	0.0075 0.190	0.0106 0.270	0.0142 0.360	0.0185 0.470	0.0232 0.590	0.0291 0.740	0.0055 0.140	0.0075 0.190	0.0045 0.114
355	400	0.0051 0.130	0.0087 0.220	0.0134 0.340	0.0177 0.450	0.0236 0.600	0.0295 0.750	0.0083 0.210	0.0118 0.300	0.0157 0.400	0.0205 0.520	0.0256 0.650	0.0323 0.820	0.0060 0.152	0.0080 0.203	0.0050 0.127

⁽¹⁾For bearings with normal initial clearance

Continued on the next page

TORRINGTON RADIAL SPHERICAL ROLLER BEARINGS (continued)

Min./Max. values for each RIC are shown in the two adjacent columns directly beneath the selected RIC. Each single column represents a boundary between adjacent RIC's. For example, the minimum values shown for C5 are also the maximum values for C4 ; minimum values for C4 are also the maximum values for C3; etc.

Bore (nominal)		Cylindrical Bore						Tapered Bore						Recommended Reduction of RIC Due to Installation		Recommended RIC after Installation ⁽¹⁾
		Normal (Standard)		C4		C5		Normal (Standard)		C4		C5				
		min.	max.	min.	max.	min.	max.	min.	max.	min.	max.	min.	max.			
mm	min.	max.	min.	max.	min.	max.	min.	max.	min.	max.	min.	max.	min.	max.	min.	
	over	incl.	inch mm	inch mm	inch mm	inch mm	inch mm	inch mm	inch mm	inch mm	inch mm	inch mm	inch mm	inch mm	inch mm	
400	450	0.0055 0.140	0.0094 0.240	0.0146 0.370	0.0197 0.500	0.0260 0.660	0.0323 0.820	0.0091 0.230	0.0130 0.330	0.0173 0.440	0.0224 0.570	0.0283 0.720	0.0358 0.910	0.0065 0.165	0.0085 0.216	0.0060 0.152
450	500	0.0055 0.140	0.0102 0.260	0.0161 0.410	0.0217 0.550	0.0283 0.720	0.0354 0.900	0.0102 0.260	0.0146 0.370	0.0193 0.490	0.0248 0.630	0.0311 0.790	0.0394 1.000	0.0070 0.178	0.0090 0.229	0.0065 0.165
500	560	0.0059 0.150	0.0110 0.280	0.0173 0.440	0.0236 0.600	0.0307 0.780	0.0394 1.000	0.0114 0.290	0.0161 0.410	0.0213 0.540	0.0268 0.680	0.0343 0.870	0.0433 1.100	0.0080 0.203	0.0100 0.254	0.0070 0.178
560	630	0.0067 0.170	0.0122 0.310	0.0189 0.480	0.0256 0.650	0.0335 0.850	0.0433 1.100	0.0126 0.320	0.0181 0.460	0.0236 0.600	0.0299 0.760	0.0386 0.980	0.0484 1.230	0.0090 0.229	0.0110 0.279	0.0080 0.203
630	710	0.0075 0.190	0.0138 0.350	0.0209 0.530	0.0276 0.700	0.0362 0.920	0.0469 1.190	0.0138 0.350	0.0201 0.510	0.0264 0.670	0.0335 0.850	0.0429 1.090	0.0535 1.360	0.0100 0.254	0.0120 0.305	0.0080 0.203
710	800	0.0083 0.210	0.0154 0.390	0.0228 0.580	0.0303 0.770	0.0398 1.010	0.0512 1.300	0.0154 0.390	0.0224 0.570	0.0295 0.750	0.0378 0.960	0.0480 1.220	0.0591 1.500	0.0110 0.279	0.0140 0.356	0.0090 0.229
800	900	0.0091 0.230	0.0169 0.430	0.0256 0.650	0.0339 0.860	0.0441 1.120	0.0567 1.440	0.0173 0.440	0.0252 0.640	0.0331 0.840	0.0421 1.070	0.0539 1.370	0.0665 1.690	0.0120 0.305	0.0150 0.381	0.0100 0.252
900	1000	0.0102 0.260	0.0189 0.480	0.0280 0.710	0.0366 0.930	0.0480 1.220	0.0618 1.57	0.0193 0.490	0.0280 0.710	0.0366 0.930	0.0469 1.190	0.0598 1.520	0.0732 1.860	0.0140 0.356	0.0170 0.432	0.0110 0.279

⁽¹⁾For bearings with normal initial clearance

RADIAL CYLINDRICAL ROLLER BEARINGS

Min./Max. values for each RIC are shown in the two adjacent columns directly beneath the selected RIC. Each single column represents a boundary between adjacent RIC's. For example, the minimum values shown for R5 are also the maximum values for R4 ; minimum values for R4 are also the maximum values for R3; etc. The desired RIC code (R1, R2, etc.) must be added to the bearing number, FOLLOWING ALL OTHER SUFFIXES.

RADIAL INTERNAL CLEARANCE LIMITS

All data on this chart are in inches/millimeters.

Bore (nominal)		R2		R4		R5	
		min.	max.	min.	max.	min.	max.
		R1	R3	R5	R5	R5	R5
Over	Incl.	min.	max.	min.	max.	min.	max.
in.	in.	in.	in.	in.	in.	in.	in.
mm	mm	mm	mm	mm	mm	mm	mm
3.1496	3.9370	0.0005	0.0016	0.0032	0.0051	0.0077	0.0107
80	100	0.013	0.041	0.081	0.130	0.196	0.272
3.9370	4.7244	0.0005	0.0018	0.0036	0.0060	0.0089	0.0122
100	120	0.013	0.046	0.091	0.152	0.226	0.310
4.7244	5.5118	0.0009	0.0022	0.0041	0.0067	0.0101	0.0139
120	140	0.023	0.056	0.104	0.170	0.256	0.353
5.5118	6.2992	0.0010	0.0026	0.0049	0.0077	0.0112	0.0151
140	160	0.025	0.066	0.124	0.196	0.284	0.384
6.2992	7.0866	0.0011	0.0027	0.0052	0.0082	0.0118	0.0158
160	180	0.028	0.069	0.132	0.208	0.300	0.401
7.0866	7.8740	0.0014	0.0032	0.0060	0.0092	0.0130	0.0172
180	200	0.036	0.081	0.152	0.234	0.330	0.437
7.8740	8.6614	0.0016	0.0034	0.0062	0.0094	0.0132	0.0174
200	220	0.041	0.086	0.157	0.239	0.335	0.4420
8.6614	10.2362	0.0022	0.0040	0.0068	0.0100	0.0138	0.018
220	260	0.056	0.102	0.173	0.254	0.351	0.455
10.2362	11.8110	0.0024	0.0042	0.0070	0.0102	0.0140	0.0182
260	300	0.061	0.107	0.178	0.259	0.356	0.462

Bore (nominal)		R2		R4		R5	
		min.	max.	min.	max.	min.	max.
		R1	R3	R5	R5	R5	R5
Over	Incl.	min.	max.	min.	max.	min.	max.
in.	in.	in.	in.	in.	in.	in.	in.
mm	mm	mm	mm	mm	mm	mm	mm
11.8110	13.7795	0.0032	0.0050	0.0078	0.0110	0.0148	0.0190
300	350	0.081	0.127	0.198	0.279	0.376	0.483
13.7795	15.7480	0.0042	0.0065	0.0093	0.0125	0.0163	0.0205
350	400	0.107	0.165	0.236	0.318	0.414	0.521
15.7480	17.7165	0.0055	0.0080	0.0110	0.0142	0.0180	0.0222
400	450	0.14	0.203	0.279	0.361	0.457	0.564
17.7165	19.6850	0.0060	0.0085	0.0115	0.0150	0.0200	0.0254
450	500	0.152	0.216	0.292	0.381	0.508	0.645
19.6850	22.0472	0.0065	0.0090	0.0120	0.0160	0.0210	0.0264
500	560	0.165	0.229	0.305	0.406	0.533	0.671
22.0472	24.8031	0.0070	0.0100	0.0140	0.0190	0.0240	0.0294
560	630	0.178	0.254	0.356	0.483	0.610	0.747
24.8031	27.9528	0.0075	0.0110	0.0150	0.0200	0.0250	0.0304
630	710	0.190	0.279	0.381	0.508	0.635	0.772
27.9528	31.4961	0.0085	0.0130	0.0180	0.0230	0.0280	0.0334
710	800	0.216	0.330	0.457	0.584	0.711	0.848

INTERNAL CLEARANCES

TORRINGTON RADIAL TAPERED ROLLER BEARINGS – TWO ROW

In two row tapered roller bearings, Internal Clearance is usually defined as Lateral Clearance (L_c) or end play, which is related to Radial Internal Clearance (RIC) by the formula:

$$L_c = \frac{RIC \times K}{0.39}$$

K being a thrust factor which is different for every bearing and is included in the table of dimensions.

L_c is determined by the relative axial position of cup and cone, and is a function of spacer width in the two element member (cup or cone). In the illustration, the cups shown in black are positioned for zero RIC, allowing no end play. The cups shown in green provide lateral clearance equal to $(B-A)$.

The desired L_c must be specified by adding designation codes G1, G2, etc. to the bearing number, FOLLOWING ALL OTHER SUFFIXES.

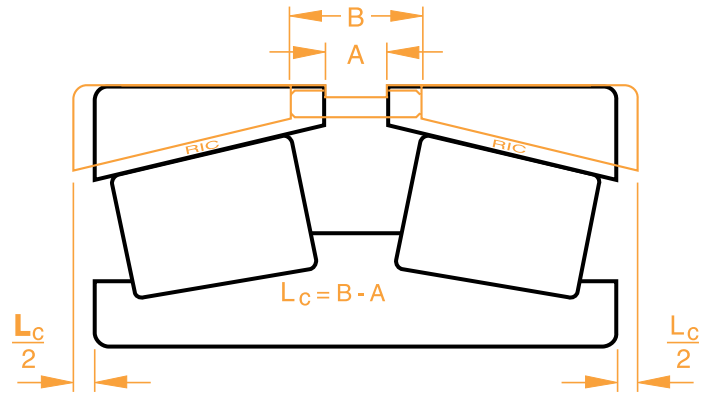

Bore		Nominal Clearance (L_c) Tolerance: ± 0.001 inch (± 0.025 mm)								
Over	Incl.	G1	G2	G3	G4	G5	G6	G7	G8	G9
in. mm	in. mm	in. mm	in. mm	in. mm	in. mm	in. mm	in. mm	in. mm	in. mm	in. mm
7.5000 190.500	12.0000 304.800	0.006 0.15	0.009 0.23	0.018 0.46	0.021 0.53	0.024 0.61	0.027 0.69	0.030 0.76	0.033 0.84	0.036 0.91
12.0000 304.800	24.0000 609.600	0.007 0.18	0.018 0.46	0.021 0.53	0.024 0.61	0.027 0.69	0.030 0.76	0.034 0.86	0.040 1.02	0.046 1.17
24.0000 609.600	36.0000 914.400	0.019 0.48	0.023 0.58	0.027 0.69	0.031 0.79	0.035 0.89	0.039 0.99	0.042 1.07	0.046 1.17	0.050 1.27

INSTALLATION PROCEDURES

A drawn cup bearing must be pressed into its housing. An installation tool similar to the one illustrated must be used in conjunction with a standard press.

It is advisable to utilize a positive stop on the press tool to locate the bearing properly in the housing. The assembly tool should have a leader or pilot, as shown, to aid in starting the bearing true in the housing.

The installation tool must be coaxial with the housing bore. The ball detent shown on the drawing is used to assist in aligning the rollers of a full complement bearing during installation and to hold the bearing on the installation tool.

Assemble the bearing with the marked end (the end with identification markings) against the angled shoulder of the pressing tool.

Never hammer the bearing into its housing even in conjunction with the proper assembly mandrel.

Never press the bearing tightly against a shoulder in the housing. If it is necessary to use a shouldered housing, the depth of the housing bore must be sufficient to ensure the housing shoulder fillet, as well as the shoulder face, clears the bearing.

To remove a drawn cup bearing from a through-bored housing, use a tool similar to the installation tool illustrated, but without the stop. For suggested methods of removing bearings from blind and shouldered bores, consult your Timken sales associate.

- A- $\frac{1}{64}$ " (0.4 mm) less than housing bore
- B- .003" (0.08 mm) less than shaft diameter
- C- distance bearing will be inset into housing, minimum of .008" (0.2 mm)
- D- pilot length should be length of bearing less $\frac{1}{32}$ " (0.8 mm)
- E- approximately $\frac{1}{2}$ D

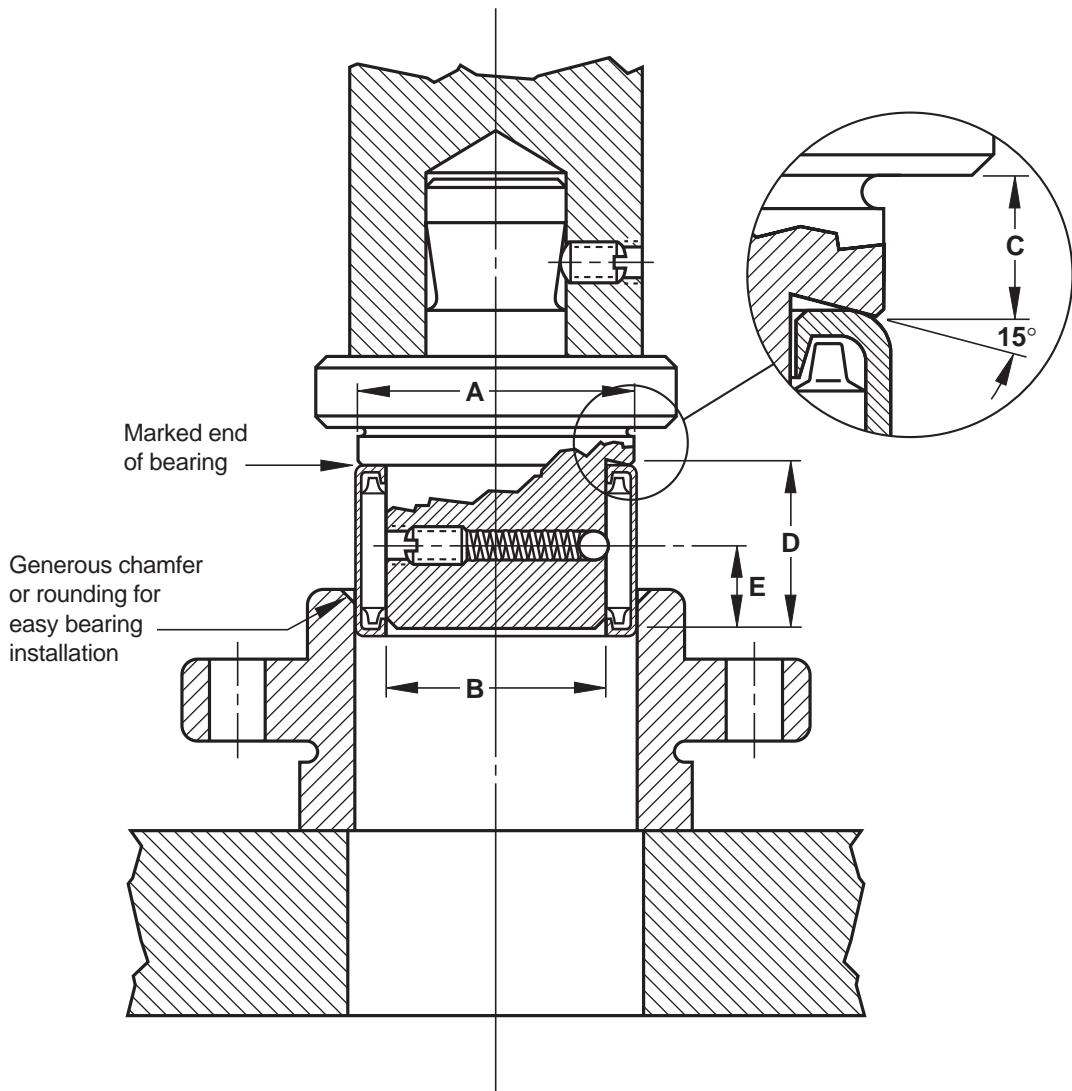

HOW TO INSPECT A BEARING JOURNAL OR HOUSING BORE

A twelve-point inspection is recommended to properly inspect a bearing journal or housing bore. Verification of mating component geometry is achieved by comparing the inspection measurements to the recommended (mating component) tolerance limits. Shaft and housing limits are selected using specific application criteria. Tables of these limits are published in The Timken Service Catalog, order no. 5731.

Diameter (size), roundness and taper (form) can be confirmed after the twelve measurements are recorded.

THE TWELVE-POINT MEASUREMENT PROCEDURE:

- 1) Use two-point gauges that are accurate to .0001". It is recommended that gauges with accuracy to $\frac{1}{10}$ of the units that are being inspected to be used (resolution to .00001"). We recognize readily available gauges read to .0001", however.
- 2) Measure four position at 0°, 45°, 90°, and 135° in three different planes of the mating surface (that is in direct contact with the bearing). The three planes should be evenly spaced across the contact area. The outboard measurements should be $\frac{1}{8}$ " to $\frac{1}{2}$ " in from each end.
- 3) Record the measurements on a chart like the one listed below. Keep all three sets of measurements oriented with respect to each other. Take an average of each plane.

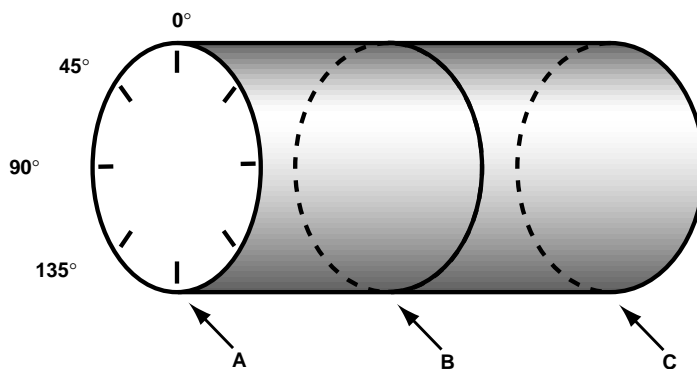

	0°	45°	90°	135°	AVERAGES
PLANE A	_____	_____	_____	_____	A = _____
PLANE B	_____	_____	_____	_____	B = _____
PLANE C	_____	_____	_____	_____	C = _____

DIAMETER (SIZE) EVALUATION:

Compare the average diameter measurement (A, B, C) to the recommended tolerance limits. Each average diameter should be within the recommended limits. The mating component diameter is out of specification if any average is over or under the recommended limits.

ROUNDNESS (FORM) EVALUATION:

Compare the individual measurements in a lane to each other. The maximum permissible deviation of these measurements is one-half ($\frac{1}{2}$) of the recommended limit. An out-of-round condition exists if differences greater than one-half ($\frac{1}{2}$) of the limit are found.

TWELVE POINT MEASUREMENT WORKSHEET

Application: _____ Machine: _____

Comments: _____

Shaft Tolerances Required: Max: _____ Min: _____ 1/2 Limit: _____

Housing Tolerances Required: Max: _____ Min: _____ 1/2 Limit: _____

MEASUREMENTS (gauges accurate to .0001" minimum is recommended)

	0°	45°	90°	135°	AVERAGES
PLANE A	_____	_____	_____	_____	A = _____
PLANE B	_____	_____	_____	_____	B = _____
PLANE C	_____	_____	_____	_____	C = _____

DIAMETER (SIZE) EVALUATION:

Compare the average diameter measurement (A, B, C) to the recommended tolerance limits. Each average diameter should be within the recommended limits. The mating component diameter is out of specification if any average is over or under the recommended limits.

ROUNDNESS (FORM) EVALUATION:

Compare the individual measurements in a plane to each other. The maximum permissible deviation of these measurements is one-half (1/2) of the recommended limit. An out-of-round condition exists if differences greater than one-half (1/2) of the limit are found.

TAPER (FORM) EVALUATION:

Taper is determined by taking the difference between the plane averages as follows:

AVERAGE A = _____	AVERAGE B = _____	AVERAGE C = _____
– AVERAGE B = _____	– AVERAGE C = _____	– AVERAGE C = _____
DIFFERENCE = _____	DIFFERENCE = _____	DIFFERENCE = _____

Excessive taper exists if the resultant differences exceed one-half (1/2) of the specified tolerance range.

SURFACE FINISH REFERENCE:

- Common surface finishes required for shafts are:
 - ≤ 2" diameter = 32rms Micro Finish maximum
 - > 2" diameter = 63rms Micro Finish maximum
- Common surface finishes required for housings are:
 - Stationary outer ring required to float = 63rms maximum
 - Stationary outer ring **not** required to float = 125rms maximum

EXAMPLE:

A 22324YMW33W800C4 "shaker screen" bearing housing inspection. This application requires a "P6" housing tolerance limit. The "P6" housing diameters are 10.2331"/ 10.2343".

Size is verified when the housing "plane" average diameters are between 10.2331" and 10.2343".

Roundness and taper inspections require that one-half (½) of the permissible tolerance limits be calculated. Thus,

$$\frac{10.2343'' - 10.2331''}{2} \text{ AND } \frac{.0012''}{2} = .0006''$$

.0012" maximum limit

Roundness is verified by comparing the differences of the four measurements of a given plane. **No** difference should exceed .0006".

Taper is verified by comparing the differences of the three **averages**. No difference should exceed .0006".

CONCLUDING COMMENTS:

Precision ground anti-friction, rolling element bearings are extremely precise and refined industrial products. Their performance and life can be greatly enhanced by the following:

- The working environment must be clean during installation.
- Accepted care, handling techniques, and tools and fixtures must be employed during removal and installation of bearings during repair.
- Mating component geometry and material should meet industry standards as published in The Timken Service Catalog.
- Common surface finishes required for shafts are:
 - ≤ 2" diameter = 32rms Micro Finish maximum
 - > 2" diameter = 63rms Micro Finish maximum
- Common surface finishes required for housings are:
 - Stationary outer ring required to float = 63rms maximum
 - Stationary outer ring **not** required to float = 125rms maximum

RADIAL BALL, SPHERICAL, CYLINDRICAL ROLLER BEARINGS

Below is a graphical representation of shaft and housing fit selection for these bearings conforming to ANSI/ABMA Standard 7. The bars designated by g6, h6 etc. represent shaft/housing diameter and tolerance ranges to achieve various loose and interference fits required for various load and ring rotation conditions.

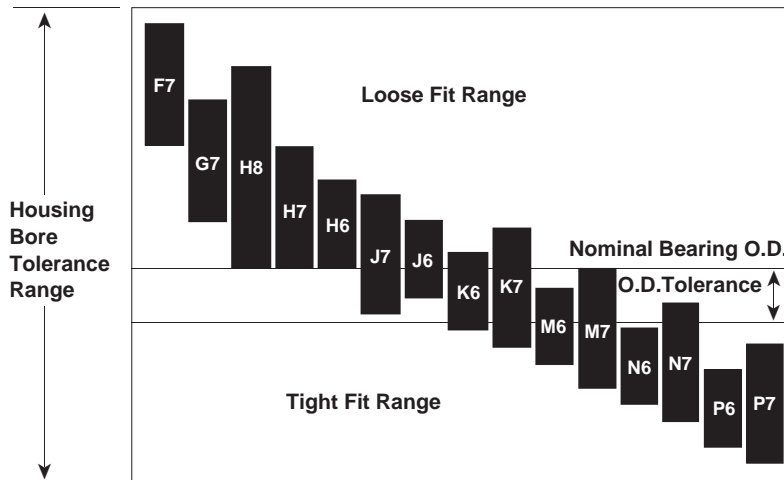
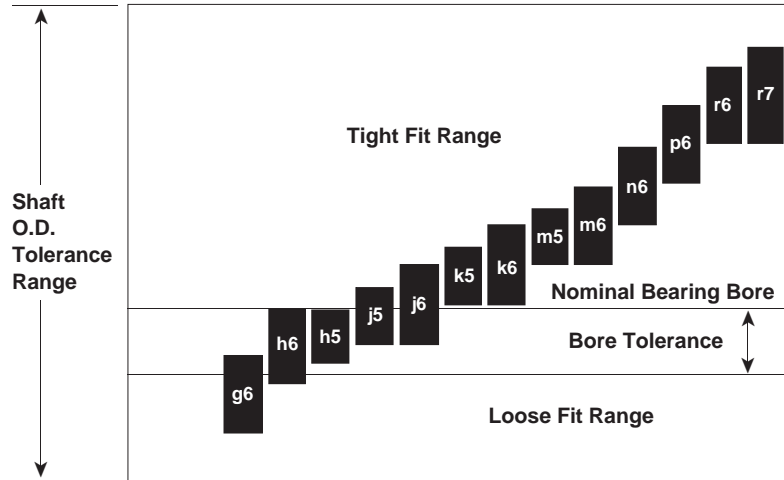

SHAFT AND HOUSING FITS

RADIAL BALL, SPHERICAL AND CYLINDRICAL ROLLER BEARINGS

Tolerance and shaft diameters shown as variance from nominal bearing bore, using the symbols in the graph. All data except nominal dimensions are in ten-thousands of an inch (5 = 0.0005") and thousandths of a millimeter or micrometer (5 = 0.005mm).

See pages 26 through 31 for actual shaft and housing diameters for normal loading of ABEC-1 and ABEC-3 radial ball bearings and 7000WN Series angular contact ball bearings.

For particular operating conditions of radial ball, spherical and cylindrical roller bearings, see pages 32, 33 and 34.

SHAFT

Bearing Bore		g6				h6			h5			j5			j6			k5			k6			m5		
Nominal (max.) Over	Incl.	Tol. +0 To	Shaft Dia.		Fit	Shaft Dia.		Fit	Shaft Dia.		Fit	Shaft Dia.		Fit	Shaft Dia.		Fit	Shaft Dia.		Fit	Shaft Dia.		Fit	Shaft Dia.		Fit
			max.	min.		max.	min.		max.	min.		max.	min.		max.	min.		max.	min.		max.	min.		max.	min.	
mm		in.	in.	in.	in.	mm	mm	mm	mm	mm	mm	mm	mm	mm	mm	mm	mm	mm	mm	mm	mm	mm	mm	mm	mm	mm
3	6	-3	-2	-5	5L 1T	0	-3	3L 3T	0	-2	2L 3T	+1	-1	1L 4T	+2	-1	1L 5T	+2	+0	0T 5T				+4	+2	2T 7T
		-8	-4	-12	12L 4T	0	-8	8L 8T	0	-5	5L 8T	+3	-2	2L 11T	+6	-2	2L 14T	+6	+1	1T 14T				+9	+4	4T 17T
6	10	-3	-2	-6	6L 1T	0	-4	4L 3T	0	-2	2L 3T	+2	-1	1L 5T	+3	-1	1L 6T	+3	+0	0T 6T				+5	+2	2T 8T
		-8	-5	-14	14L 3T	0	-9	9L 8T	0	-6	6L 8T	+4	-2	2L 12T	+7	-2	2L 15T	+7	+1	1T 15T				+12	+6	6T 20T
10	18	-3	-2	-7	7L 1T	0	-4	4L 3T	0	-3	3L 3T	+2	-1	1L 5T	+3	-1	1L 6T	+4	+0	0T 7T				+6	+3	3T 9T
		-8	-6	-17	17L 2T	0	-11	11L 8T	0	-8	8L 8T	+5	-3	3L 13T	+8	-3	3L 16T	+9	+1	1T 17T				+15	+7	7T 23T
18	30	-4	-3	-8	8L 1T	0	-5	5L 4T				+2	-2	2L 6T	+4	-2	2L 8T	+4	+1	1T 8T				+7	+3	3T 11T
		-10	-7	-20	20L 3T	0	-13	13L 10T				+5	-4	4L 15T	+9	-4	4L 19T	+11	+2	2T 21T				+17	+8	8T 27T
30	50	-4.5	-4	-10	10L 0.5T	0	-6	6L 4.5T				+2	-2	2L 6.5T	+4	-2	2L 8.5T	+5	+1	1T 9.5T	+7	+1	1T 11.5T	+8	+4	4T 12.5T
		-12	-9	-25	25L 3T	0	-16	16L 12T				+6	-5	5L 18T	+11	-5	5L 23T	+13	+2	2T 25T	+18	+2	2T 30T	+20	+9	9T 32T
50	80	-6	-4	-11	11L 2T	0	-7	7L 6T				+2	-3	3L 8T	+5	-3	3L 11T	+6	+1	1T 12T	+8	+1	1T 14T	+9	+4	4T 15T
		-15	-10	-29	29L 5T	0	-19	19L 15T				+6	-7	7L 21T	+12	-7	7L 27T	+15	+2	2T 30T	+21	+2	2T 36T	+24	+11	11T 39T
80	120	-8	-5	-13	13L 3T	0	-9	9L 8T				+2	-4	4L 10T	+5	-4	4L 13T	+7	+1	1T 15T	+10	+1	1T 18T	+11	+5	5T 19T
		-20	-12	-34	34L 8T	0	-22	22L 20T				+6	-9	9L 26T	+13	-9	9L 33T	+18	+3	3T 38T	+25	+3	3T 45T	+28	+13	13T 48T
120	180	-10	-6	-15	15L 4T	0	-10	10L 10T				+3	-4	4L 13T	+6	-4	4L 16T	+8	+1	1T 18T	+11	+1	1T 21T	+13	+6	6T 23T
		-25	-14	-39	39L 11T	0	-25	25L 25T				+7	-11	11L 32T	+14	-11	11L 39T	+21	+3	3T 46T	+28	+3	3T 53T	+33	+15	15T 58T
180	200	-12	-6	-17	17L 6T	0	-11	11L 12T				+3	-5	5L 15T	+6	-5	5L 18T	+9	+2	2T 21T				+15	+7	7T 27T
		-30	-15	-44	44L 15T	0	-29	29L 30T				+7	-13	13L 37T	+16	-13	13L 46T	+24	+4	4T 54T				+37	+17	17T 67T
200	225	-12	-6	-17	17L 6T	0	-11	11L 12T				+3	-5	5L 15T	+6	-5	5L 18T	+9	+2	2T 21T				+15	+7	7T 27T
		-30	-15	-44	44L 15T	0	-29	29L 30T				+7	-13	13L 37T	+16	-13	13L 46T	+24	+4	4T 54T				+37	+17	17T 67T
225	250	-12	-6	-17	17L 6T	0	-11	11L 12T				+3	-5	5L 15T	+6	-5	5L 18T	+9	+2	2T 21T				+15	+7	7T 27T
		-30	-15	-44	44L 15T	0	-29	29L 30T				+7	-13	13L 37T	+16	-13	13L 46T	+24	+4	4T 54T				+37	+17	17T 67T
250	280	-14	-7	-19	19L 7T	0	-13	13L 14T				+3	-6	6L 17T	+6	-6	6L 20T	+11	+2	2T 25T				+17	+8	8T 31T
		-35	-17	-49	49L 18T	0	-32	32L 35T				+7	-16	16L 42T	+16	-16	16L 51T	+27	+4	4T 62T				+43	+20	20T 78T
280	315	-14	-7	-19	19L 7T	0	-13	13L 14T				+3	-6	6L 17T	+6	-6	6L 20T	+11	+2	2T 25T				+17	+8	8T 31T
		-35	-17	-49	49L 18T	0	-32	32L 35T				+7	-16	16L 42T	+16	-16	16L 51T	+27	+4	4T 62T				+43	+20	20T 78T

The tolerances in this table are in conformance with ANSI/ABMA Standard 7-1988

RADIAL BALL, SPHERICAL AND CYLINDRICAL ROLLER BEARINGS

Tolerance and shaft diameters shown as variance from nominal bearing bore, using the symbols in the graph. All data except nominal dimensions are in ten-thousands of an inch (5 = 0.0005") and thousandths of a millimeter or micrometer (5 = 0.005mm).

See pages 26 through 31 for actual shaft and housing diameters for normal loading of ABEC-1 and ABEC-3 radial ball bearings and 7000WN Series angular contact ball bearings.

For particular operating conditions of radial ball, spherical and cylindrical roller bearings, see pages 32, 33 and 34.

SHAFT

Bearing Bore		m6			n6			p6			r6			r7			
Nominal (max.) Over	Incl.	To. +0 To	Shaft	Dia.	Fit	Shaft	Dia.	Fit	Shaft	Dia.	Fit	Shaft	Dia.	Fit	Shaft	Dia.	Fit
			max.	min.		max.	min.		max.	min.		max.	min.		max.	min.	
mm		in. mm	in. mm	in. mm	in. mm	in. mm	in. mm	in. mm	in. mm	in. mm	in. mm	in. mm	in. mm	in. mm	in. mm	in. mm	in. mm
3	6	-3 -8															
6	10	-3 -8															
10	18	-3 -8															
18	30	-4 -10															
30	50	-5 -12	+10 +25	+4 +9	4T 14.5T 9T 37T												
50	80	-6 -15	+12 +30	+4 +11	4T 18T 11T 45T	+15 +39	+8 +20	8T 21T 20T 54T									
80	120	-8 -20	+14 +35	+5 +13	5T 22T 13T 55T	+18 +45	+9 +23	9T 26T 23T 65T	+23 +59	+15 +37	15T 31T 37T 79T						
120	180	-10 -25	+16 +40	+6 +15	6T 26T 15T 65T	+20 +52	+11 +27	11T 30T 27T 77T	+27 +68	+17 +43	17T 37T 43T 93T	+35 +90	+26 +65	26T 45T 65T 115T			
180	200	-12 -30	+18 +46	+7 +17	7T 30T 17T 76T	+24 +60	+12 +31	12T 36T 31T 90T	+31 +79	+20 +50	20T 43T 50T 109T	+42 +106	+30 +77	30T 54T 77T 136T			
200	225	-12 -30	+18 +46	+7 +17	7T 30T 17T 76T	+24 +60	+12 +31	12T 36T 31T 90T	+31 +79	+20 +50	20T 43T 50T 109T	+43 +109	+31 +80	31T 55T 80T 139T	+50 +126	+31 +80	31T 62T 80T 156T
225	250	-12 -30	+18 +46	+7 +17	7T 30T 17T 76T	+24 +60	+12 +31	12T 36T 31T 90T	+31 +79	+20 +50	20T 43T 50T 109T	+44 +113	+33 +84	33T 56T 84T 143T	+51 +130	+33 +84	33T 63T 84T 160T
250	280	-14 -35	+20 +52	+8 +20	8T 34T 20T 87T	+26 +66	+13 +34	13T 40T 34T 101T	+35 +88	+22 +56	22T 49T 56T 123T	+50 +126	+37 +94	37T 64T 94T 161T	+57 +146	+37 +94	37T 71T 94T 181T
280	315	-14 -35	+20 +52	+8 +20	8T 34T 20T 87T	+26 +66	+13 +34	13T 40T 34T 101T	+35 +88	+22 +56	22T 49T 56T 123T	+51 +130	+39 +98	39T 65T 98T 165T	+59 +150	+39 +98	39T 73T 98T 185T

The tolerances in this table are in conformance with ANSI/ABMA Standard 7-1988

Continued on the next page

SHAFT AND HOUSING FITS

RADIAL BALL, SPHERICAL AND CYLINDRICAL ROLLER BEARINGS (continued)

Tolerance and shaft diameters shown as variance from nominal bearing bore, using the symbols in the graph. All data except nominal dimensions are in ten-thousands of an inch (5 = 0.0005") and thousandths of a millimeter or micrometer (5 = 0.005mm).

See pages 26 through 31 for actual shaft and housing diameters

for normal loading of ABEC-1 and ABEC-3 radial ball bearings and 7000WN Series angular contact ball bearings.

For particular operating conditions of radial ball, spherical and cylindrical roller bearings, see pages 32, 33 and 34.

SHAFT

Bearing Bore		g6			h6			h5			j5			j6			k5			k6			m5			
Nominal (max.) Over	Incl.	To. +0 To		Fit	Shaft Dia.		Fit	Shaft Dia.		Fit	Shaft Dia.		Fit	Shaft Dia.		Fit	Shaft Dia.		Fit	Shaft Dia.		Fit	Shaft Dia.		Fit	
		max.	min.		max.	min.		max.	min.		max.	min.		max.	min.		max.	min.		max.	min.		max.	min.		max.
mm		in.	mm	in.	mm	in.	mm	in.	mm	in.	mm	in.	mm	in.	mm	in.	mm	in.	mm	in.	mm	in.	mm	in.	mm	
315	355	-16	-7	-21	21L	0	-14	14L				+3	-7	7L	+7	-7	7L	+11	+2	2T				+18	+8	8T
					9T			16T						19T			23T			27T						34T
		-40	-18	-54	54L	0	-36	36L					+7	-18	18L	+18	-18	18L	+29	+46	4T				+46	+21
					22T			40T						47T			58T			9T						86T
355	400	-16	-7	-21	21L	0	-14	14L				+3	-7	7L	+7	-7	7L	+11	+2	2T				+18	+8	8T
					9T			16T						19T			23T			27T						34T
		-40	-18	-54	54L	0	-36	36L					+7	-18	18L	+18	-18	18L	+29	+4	4T				+46	+21
					22T			40T						47T			58T			69T						86T
400	450	-18	-8	-24	24L	0	-16	16L				+3	-8	8L	+8	-8	8L	+13	+2	2T				+20	+9	9T
					10T			18T						21T			26T			31T						38T
		-45	-20	-60	60L	0	-40	40L					+7	-20	20L	+20	-20	20L	+32	5	5T				+50	+23
					25T			45T					52T			65T			77T							95T
450	500	-18	-8	-24	24L	0	-16	16L				+3	-8	8L	+8	-8	8L	+13	2	2T				+20	+9	9T
					10T			18T						21T			26T			31T						38T
		-45	-20	-60	60L	0	-40	40L					+7	-20	20L	+20	-20	20L	+32	5	5T				+50	+23
					25T			45T					52T			65T			77T							95T
500	560	-20	-9	-26	26L	0	-17	17L				+3	-9	9L	+9	-9	9L	+12	0	0T				+22	+10	10T
					11T			20T						23T			29T			32T						42T
		-50	-22	-66	66L	0	-44	44L					+8	-22	22L	+22	-22	22L	+30	0	0T				+56	+26
					28T			50T					58T			72T			80T							106T
560	630	-20	-9	-26	26L	0	-17	17L				+3	-9	9L	+9	-9	9L	+12	0	0T				+22	+10	10T
					11T			20T						23T			29T			32T						42T
		-50	-22	-66	66L	0	-44	44L					+8	-22	22L	+22	-22	22L	+30	0	0T				+56	+26
					28T			50T					58T			72T			80T							106T
630	710	-30	-9	-29	29L	0	-20	20L				+4	-10	10L	+10	-10	10L	+14	0	0T				+26	+12	12T
					21T			30T						34T			40T			44T						56T
		-75	-24	-74	74L	0	-50	50L					+10	-25	25L	+25	-25	25L	+35	0	0T				+65	+30
					51T			75T					85T			100T			110T							140T
710	800	-30	-9	-29	29L	0	-20	20L				+4	-10	10L	+10	-10	10L	+14	0	0T				+26	+12	12T
					21T			30T						34T			40T			44T						56T
		-75	-24	-74	74L	0	-50	50L					+10	-25	25L	+25	-25	25L	+35	0	0T				+65	+30
					51T			75T					85T			100T			110T							140T
800	900	-39	-10	-32	32L	0	-22	22L				+5	-11	11L	+11	-11	11L	+16	0	0T				+29	+13	13T
					29T			39T						44T			50T			55T						68T
		-100	-26	-82	82L	0	-56	56L					+12	-28	28L	+28	-28	28L	+40	0	0T				+74	+34
					74T			100T					112T			128T			140T							174T
900	1000	-39	-10	-32	32L	0	-22	22L				+5	-11	11L	+11	-11	11L	+16	0	0T				+29	+13	13T
					29T			39T						44T			50T			55T						68T
		-100	-26	-82	82L	0	-56	56L					+12	-28	28L	+28	-28	28L	+40	0	0T				+74	+34
					74T			100T					112T			128T			140T							174T
1000	1120	-49	-11	-37	37L	0	-26	26L				+5	-13	13L	+13	-13	13L	+18	0	0T				+34	+16	16T
					38T			49T						54T			62T			67T						83T
		-125	-28	-94	94L	0	-66	66L					+13	-33	33L	+33	-33	33L	+46	0	0T				+86	+40
					97T			125T					138T			158T			171T							211T
1120	1250	-49	-11	-37	37L	0	-26	26L				+5	-13	13L	+13	-13	13L	+18	0	0T				+34	+16	16T
					38T			49T						54T			62T			67T						83T
		-125	-28	-94	94L	0	-66	66L					+13	-33	33L	+33	-33	33L	+46	0	0T				+86	+40
					97T			125T					138T			158T			171T							211T

The tolerances in this table are in conformance with ANSI/ABMA Standard 7-1988

RADIAL BALL, SPHERICAL AND CYLINDRICAL ROLLER BEARINGS (continued)

Tolerance and shaft diameters shown as variance from nominal bearing bore, using the symbols in the graph. All data except nominal dimensions are in ten-thousandths of an inch (5 = 0.0005") and thousandths of a millimeter or micrometer (5 = 0.005mm).

for normal loading of ABEC-1 and ABEC-3 radial ball bearings and 7000WN Series angular contact ball bearings.

For particular operating conditions of radial ball, spherical and cylindrical roller bearings, see pages 32, 33 and 34.

See pages 26 through 31 for actual shaft and housing diameters

SHAFT

Bearing Bore		m6			n6			p6			r6			r7			
Nominal (max.) Over Incl.	To. +0 To	Shaft	Dia.	Fit	Shaft	Dia.	Fit	Shaft	Dia.	Fit	Shaft	Dia.	Fit	Shaft	Dia.	Fit	
		max.	min.		max.	min.		max.	min.		max.	min.		max.	min.		
mm	mm	in.	in.	in.	in.	in.	in.	in.	in.	in.	in.	in.	in.	in.	in.	in.	
315	355	-16	+22	+8	8T 38T	+29	+15	15T 45T	+39	+24	24T 55T	+57	+43	43T 73T	+65	+43	43T 81T
		-40	+57	+21	21T 97T	+73	+37	37T 113T	+98	+62	62T 138T	+144	+108	108T 184T	+165	+108	108T 205T
355	400	-16				+29	+15	15T 45T	+39	+24	24T 55T	+59	+45	45T 75T	+67	+45	45T 83T
		-40				+73	+37	37T 113T	+98	+62	62T 138T	+150	+114	114T 190T	+171	+114	114T 211T
400	450	-18				+31	+16	16T 49T	+43	+27	27T 61T	+65	+50	50T 83T	+74	+50	50T 92T
		-45				+80	+40	40T 125T	+108	+68	68T 153T	+166	+126	126T 211T	+189	+126	126T 234T
450	500	-18				+31	+16	16T 49T	+43	+27	27T 61T	+68	+52	52T 86T	+77	+52	52T 95T
		-45				+80	+40	40T 125T	+108	+68	68T 153T	+172	+132	132T 217T	+195	+132	132T 240T
500	560	-20							+48	+31	31T 68T	+76	+59	59T 96T	+87	+59	59T 107T
		-50							+122	+78	78T 172T	+194	+150	150T 244T	+220	+150	150T 270T
560	630	-20							+48	+31	31T 68T	+78	+61	61T 98T	+89	+61	61T 109T
		-50							+122	+78	78T 172T	+199	+155	155T 249T	+225	+155	155T 275T
630	710	-30							+54	+35	35T 84T	+89	+69	69T 119T	+100	+69	69T 130T
		-75							+138	+88	88T 213T	+225	+175	175T 300T	+255	+175	175T 330T
710	800	-30							+54	+35	35T 84T	+93	+73	73T 123T	+104	+73	73T 134T
		75							+138	+88	88T 213T	+235	+185	185T 310T	+265	+185	185T 340T
800	900	-39							+61	+39	39T 100T	+105	+83	83T 144T	+118	+83	83T 157T
		-100							156	+100	100T 256T	+266	+210	210T 366T	+300	+210	210T 400T
900	1000	-39							+61	+39	39T 100T	+109	+87	87T 148T	+122	+87	87T 161T
		-100							+156	+100	100T 256T	+276	+220	220T 376T	+310	+220	220T 410T
1000	1120	-49							+73	+47	47T 122T	+124	+98	98T 173T	+140	+98	98T 189T
		-125							+186	+120	120T 311T	+316	+250	250T 441T	+355	+250	250T 480T
1120	1250	-49							+73	+47	47T 122T	+128	+102	102T 177T	+144	+102	102T 193T
		-125							+186	+120	120T 311T	+326	+260	260T 451T	+365	+260	260T 490T

The tolerances in this table are in conformance with ANSI/ABMA Standard 7- 1988.

SHAFT AND HOUSING FITS

RADIAL BALL, SPHERICAL AND CYLINDRICAL ROLLER BEARINGS

Tolerance and housing bore shown as variance from nominal bearing O.D. All data except nominal dimensions are in ten-thousands of an inch (5 = 0.0005") and thousandths of a millimeter or micrometer (5 = 0.005mm).

See pages 26 through 31 for actual shaft and housing diameters

for normal loading of ABEC-1 and ABEC-3 radial ball bearings and 7000WN Series angular contact ball bearings.

For particular operating conditions of radial ball, spherical and cylindrical roller bearings, see pages 32, 33 and 34.

HOUSING

Bearing O.D.		F7			G7			H8			H7			H6			J6			J7			K6			K7		
Nominal (max.) Over Incl.	Tol. +0 To	Housing Bore		Fit	Housing Bore		Fit	Housing Bore		Fit	Housing Bore		Fit	Housing Bore		Fit	Housing Bore		Fit	Housing Bore		Fit	Housing Bore		Fit	Housing Bore		Fit
		min.	max		min.	max		min.	max		min.	max		min.	max		min.	max		min.	max		min.	max		min.	max	
mm	in.	in.	in.	in.	in.	in.	in.	in.	in.	in.	in.	in.	in.	in.	in.	in.	in.	in.	in.	in.	in.	in.	in.	in.	in.	in.	in.	in.
10 18	-3	+6	+13	6L 16L	+2	+9	2L 12L	0	+11	0L 14L	0	+7	0L 10L	0	+4	0L 7L	-2	+2	5L	-3	+4	7L	-4	+1	4L	-5	+2	5L
	-8	+16	+34	16L 42L	+6	+24	6L 32L	0	+27	0L 35L	0	+18	0L 26L	0	+11	0L 19L	-5	+6	5T 14L	-8	+10	8T 18L	-9	+2	9T 10L	-12	+6	12T 14L
18 30	-3.5	+8	+16	8L 19.5L	+3	+11	3L 14.5L	0	+13	0L 16.5L	0	+8	0L 11.5L	0	+5	0L 8.5L	-2	+3	2T 6.5L	-4	+5	4T 8.5L	-4	+1	4T 4.5L	-6	+2	6T 5.5L
	-9	+20	+41	20L 50L	+7	+28	7L 37L	0	+33	0L 42L	0	+21	0L 30L	0	+13	0L 22L	-5	+8	5T 17L	-9	+12	9T 21L	-11	+2	11T 11L	-15	+6	15T 15L
30 50	-4.5	+10	+20	10L 24.5L	+4	+13	4L 17.5L	0	+15	0L 19.5L	0	+10	0L 14.5L	0	+6	0L 10.5L	-2	+4	2T 8.5L	-4	+6	4T 10.5L	-5	+1	5T 5.5L	-7	+3	7T 7.5L
	-11	+25	+50	25L 61L	+9	+34	9L 45L	0	+39	0L 50L	0	+25	0L 36L	0	+16	0L 27L	-6	+10	6T 21L	-11	+14	11T 25L	-13	+3	13T 14L	-18	+7	18T 18L
50 80	-5	+12	+24	12L 29L	+4	+16	4L 21L	0	+18	0L 23L	0	+12	0L 17L	0	+7	0L 12L	-2	+5	2T 10L	-5	+7	5T 12L	-6	+2	6T 7L	-8	+4	8T 9L
	-13	+30	+60	30L 73L	+10	+40	10L 53L	0	+46	0L 59L	0	+30	0L 43L	0	+19	0L 32L	-6	+13	6T 26L	-12	+18	12T 31L	-15	+4	15T 17L	-21	+9	21T 22L
80 120	-6	+14	+28	14L 34L	+5	+19	5L 25L	0	+21	0L 27L	0	+14	0L 20L	0	+9	0L 15L	-2	+6	2T 12L	-5	+9	5T 15L	-7	+2	7T 8L	-10	+4	10T 10L
	-15	+36	+71	36L 86L	+12	+47	12L 62L	0	+54	0L 69L	0	+35	0L 50L	0	+22	0L 37L	-6	+16	6T 31L	-13	+22	13T 37L	-18	+4	18T 19L	-25	+10	25T 25L
120 150	-7	+17	+33	17L 40L	+6	+21	6L 28L	0	+25	0L 32L	0	+16	0L 23L	0	+10	0L 17L	-3	+7	3T 14L	-6	+10	6T 17L	-8	+2	8T 9L	-11	+5	11T 12L
	-18	+43	+83	43L 101L	+14	+54	14L 72L	0	+63	0L 81L	0	+40	0L 58L	0	+25	0L 43L	-7	+18	7T 36L	-14	+26	14T 44L	-21	+4	21T 22L	-28	+12	28T 30L
150 180	-10	+17	+33	17L 43L	+6	+21	6L 31L	0	+25	0L 35L	0	+16	0L 26L	0	+10	0L 20L	-3	+7	3T 17L	-6	+10	6T 20L	-8	+2	8T 12L	-11	+5	11T 15L
	-25	+43	+83	43L 108L	+14	+54	14L 79L	0	+63	0L 88L	0	+40	0L 65L	0	+25	0L 50L	-7	+18	7T 43L	-14	+26	14T 51L	-21	+4	21T 29L	-28	+12	28T 37L
180 250	-12	+20	+38	20L 50L	+6	+24	6L 36L	0	+28	0L 40L	0	+18	0L 30L	0	+11	0L 23L	-3	+9	3T 21L	-6	+12	6T 24L	-9	+2	9T 14L	-13	+5	13T 17L
	-30	+50	+96	50L 126L	+15	+61	15L 91L	0	+72	0L 102L	0	+46	0L 76L	0	+29	0L 59L	-7	+22	7T 52L	-16	+30	16T 60L	-24	+5	24T 35L	-33	+13	33T 43L
250 315	-14	+22	+43	22L 57L	+7	+27	7L 41L	0	+32	0L 46L	0	+20	0L 34L	0	+13	0L 27L	-3	+10	3T 24L	-6	+14	6T 28L	-11	+2	11T 16L	-14	+6	14T 20L
	-35	+56	+108	56L 143L	+17	+69	17L 104L	0	+81	0L 116L	0	+52	0L 87L	0	+32	0L 67L	-7	+25	7T 60L	-16	+36	16T 71L	-27	+5	27T 40L	-36	+16	36T 51L

The tolerances in this table are in conformance with ANSI/ABMA Standard 7-1988.

RADIAL BALL, SPHERICAL AND CYLINDRICAL ROLLER BEARINGS

Tolerance and housing bore shown as variance from nominal bearing O.D. All data except nominal dimensions are in ten-thousands of an inch (5 = 0.0005") and thousandths of a millimeter or micrometer (5 = 0.005mm).

For normal loading of ABEC-1 and ABEC-3 radial ball bearings and 7000WN Series angular contact ball bearings.

For particular operating conditions of radial ball, spherical and cylindrical roller bearings, see pages 32, 33 and 34.

See pages 26 through 31 for actual shaft and housing diameters

HOUSING

Bearing O.D.		M6			M7			N6			N7			P6			P7		
Nominal (max.) Over Incl.	Tol. +0 To	Housing Bore		Fit	Housing Bore		Fit	Housing Bore		Fit	Housing Bore		Fit	Housing Bore		Fit	Housing Bore		Fit
		min.	max.		min.	max.		min.	max.		min.	max.		min.	max.		min.	max.	
mm	mm	in.	in.	in.	in.	in.	in.	in.	in.	in.	in.	in.	in.	in.	in.	in.	in.	in.	in.
10 18	-3	-6	-2	6T 1L	-7	0	7T 3L	-8	-4	8T 1T	-9	-2	9T 1L	-10	-6	10T 3T	-11	-4	11T 1T
	-8	-15	-4	15T 4L	-18	0	18T 8L	-20	-9	20T 1T	-23	-5	23T 3L	-26	-15	26T 7T	-29	-11	29T 3T
18 30	-3.5	-7	-2	7T 1.5L	-8	0	8T 3.5L	-9	-4	9T 0.5T	-11	-3	11T 0.5L	-12	-7	12T 3.5T	-14	-6	14T 2.5T
	-9	-17	-4	17T 5L	-21	0	21T 9L	-24	-11	24T 2T	-28	-7	28T 2L	-31	-18	31T 9T	-35	-14	35T 5T
30 50	-4.5	-8	-2	8T 2.5L	-10	0	10T 4.5L	-11	-5	11T 0.5T	-13	-3	13T 1.5L	-15	-8	15T 3.5T	-17	-7	17T 2.5T
	-11	-20	-4	20T 7L	-25	0	25T 11L	-28	-12	28T 1T	-33	-8	33T 3L	-37	-21	37T 10T	-42	-17	42T 6T
50 80	-5	-9	-2	9T 3L	-12	0	12T 5L	-13	-6	13T 1T	-15	-4	15T 1L	-18	-10	18T 5T	-20	-8	20T 3T
	-13	-24	-5	24T 8L	-30	0	30T 13L	-33	-14	33T 1T	-39	-9	39T 4L	-45	-26	45T 13T	-51	-21	51T 8T
80 120	-6	-11	-2	11T 4L	-14	0	14T 6L	-15	-6	15T 0T	-18	-4	18T 2L	-20	-12	20T 6T	-23	-9	23T 3T
	-15	-28	-6	28T 9L	-35	0	35 15L	-38	-16	38T 1T	-45	-10	45T 5L	-52	-30	52T 15T	-59	-24	59T 9T
120 150	-7	-13	-3	13T 4L	-16	0	16T 7L	-18	-8	18T 1T	-20	-5	20T 2L	-24	-14	24T 7T	-27	-11	27T 4T
	-18	-33	-8	33T 10L	-40	0	40T 18L	-45	-20	45T 2T	-52	-12	52T 6L	-61	-36	61T 18T	-68	-28	68T 10T
150 180	-10	-13	-3	13T 7L	-16	0	16T 10L	-18	-8	18T 2L	-20	-5	20T 5L	-24	-14	24T 4T	-27	-11	27T 1T
	-25	-33	-8	33T 17L	-40	0	40T 25L	-45	-20	45T 5L	-52	-12	52T 13L	-61	-36	61T 11T	-68	-28	68T 3T
180 250	-12	-15	-3	15T 9L	-18	0	18T 12L	-20	-9	20T 3L	-24	-6	24T 6L	-28	-16	28T 4T	-31	-13	31T 1T
	-30	-37	-8	37T 22L	-46	0	46T 30L	-51	-22	51T 8L	-60	-14	60T 16L	-70	-41	70T 11T	-79	-33	79T 3T
250 315	-14	-16	-4	16T 10L	-20	0	20T 14L	-22	-10	22T 4L	-26	-6	25T 8L	-31	-19	31T 5T	-35	-14	35T 0L
	-35	-41	-9	41T 26L	-52	0	52T 35L	-57	-25	57T 10L	-66	-14	66T 21L	-79	-47	79T 12T	-88	-36	88T 1T

The tolerances in this table are in conformance with ANSI/ABMA Standard 7 – 1988.

Continued on the next page

SHAFT AND HOUSING FITS

RADIAL BALL, SPHERICAL AND CYLINDRICAL ROLLER BEARINGS (continued)

Tolerance and housing bore shown as variance from nominal bearing O.D. All data except nominal dimensions are in ten-thousands of an inch (5 = 0.0005") and thousandths of a millimeter or micrometer (5 = 0.005mm).

See pages 26 through 31 for actual shaft and housing diameters

for normal loading of ABEC-1 and ABEC-3 radial ball bearings and 7000WN Series angular contact ball bearings.

For particular operating conditions of radial ball, spherical and cylindrical roller bearings, see pages 32, 33 and 34.

HOUSING

Bearing O.D.		F7			G7			H8			H7			H6			J6			J7			K6			K7		
Nominal (max.) Over	Tol. + 0 To Incl.	Housing Bore		Fit	Housing Bore		Fit	Housing Bore		Fit	Housing Bore		Fit	Housing Bore		Fit	Housing Bore		Fit	Housing Bore		Fit	Housing Bore		Fit			
		min.	max		min.	max		min.	max		min.	max		min.	max		min.	max		min.	max		min.	max		min.	max	min.
mm	mm	in.	mm	in.	mm	in.	mm	in.	mm	in.	mm	in.	mm	in.	mm	in.	mm	in.	mm	in.	mm	in.	mm	in.	mm	in.		
315	400	-16	+24	+47	24L	7L	0	+35	0L	0	+22	0L	0	+14	0L	-3	+11	3T	-7	+15	7T	-11	+3	11T	-16	+7	16T	
		-40	+62	+119	63L	46L	0	+89	0L	0	+57	0L	0	+36	0L	-7	+29	27L	-18	+39	31L	-29	+7	19L	-40	+17	23L	
400	500	-18	+27	+52	27L	8L	0	+38	0L	0	+25	0L	0	+16	0L	-3	+13	3T	-8	+17	8T	-13	+3	13T	-18	+7	18T	
		-45	+68	+131	70L	51L	0	+97	0L	0	+63	0L	0	+40	0L	-7	+33	31L	-20	+43	35L	-32	+8	21L	-45	+18	25L	
500	630	-20	+30	+57	30L	9L	0	+43	0L	0	+28	0L	0	+17	0L	-3	+15	3T	-9	+19	9T	-17	0	17T	-28	0	28T	
		-50	+76	+146	77L	56L	0	+110	0L	0	+70	0L	0	+44	0L	-7	+37	35L	-22	+48	39L	-44	0	20L	-70	0	70T	
630	800	-30	+31	+63	31L	9L	0	+49	0L	0	+31	0L	0	+20	0L	-4	+16	4T	-9	+22	9T	-20	0	20T	-31	0	31T	
		-75	+80	+160	93L	71L	0	+125	0L	0	+80	0L	0	+50	0L	-10	+40	46L	-24	+56	52L	-50	0	30L	-80	0	80T	
800	1000	-39	+34	+69	34L	10L	0	+55	0L	0	+35	0L	0	+22	0L	-4	+18	4T	-10	+25	10T	-22	0	22T	-35	0	35T	
		-100	+86	+176	108L	85L	0	+140	0L	0	+90	0L	0	+56	0L	-10	+46	57L	-26	+64	64L	-56	0	29T	-90	0	90T	
1000	1250	-49	+39	+80	39L	11L	0	+65	0L	0	+41	0L	0	+26	0L	-4	+22	4T	-11	+30	11T	-26	0	26T	-41	0	41T	
		-125	+98	+203	129L	101L	0	+165	0L	0	+105	0L	0	+66	0L	-10	+56	71L	-28	+77	79L	-66	0	49L	-105	0	105T	
1250	1600	-63	+43	+93	43L	12L	0	+77	0L	0	+49	0L	0	+31	0L	-4	+27	4T	-12	+37	12T	-31	0	31T	-49	0	49T	
		-160	+110	+235	156L	124L	0	+195	0L	0	+125	0L	0	+78	0L	-10	+68	90L	-30	+95	100L	-78	0	63L	-125	0	125T	
1600	2000	-79	+47	+106	47L	13L	0	+91	0L	0	+59	0L	0	+36	0L	-4	+32	4T	-13	+46	13T	-36	0	36T	-59	0	59T	
		-200	+120	+270	185L	151L	0	+230	0L	0	+150	0L	0	+92	0L	-10	+82	111L	-32	+118	125L	-92	0	79L	-150	0	150T	
2000	2500	-98	+51	+120	51L	13L	0	+110	0L	0	+69	0L	0	+43	0L	-4	+39	4T	-13	+56	13T	-43	0	43T	-69	0	69T	
		-250	+130	+305	218L	180L	0	+280	0L	0	+175	0L	0	+110	0L	-10	+100	154L	-34	+141	154L	-110	0	98L	-175	0	175T	

The tolerances in this table are in conformance with ANSI/ABMA Standard 7 - 1988.

RADIAL BALL, SPHERICAL AND CYLINDRICAL ROLLER BEARINGS (continued)

Tolerance and housing bore shown as variance from nominal bearing O.D. All data except nominal dimensions are in ten-thousandths of an inch (5 = 0.0005") and thousandths of a millimeter or micrometer (5 = 0.005mm).
See pages 26 through 31 for actual shaft and housing diameters

for normal loading of ABEC-1 and ABEC-3 radial ball bearings and 7000WN Series angular contact ball bearings.

For particular operating conditions of radial ball, spherical and cylindrical roller bearings, see pages 32, 33 and 34.

HOUSING

Bearing O.D.		M6			M7			N6			N7			P6			P7		
Nominal (max.) Over Incl.	Tol. + 0 To	Housing Bore		Fit	Housing Bore		Fit	Housing Bore		Fit	Housing Bore		Fit	Housing Bore		Fit	Housing Bore		Fit
		min.	max		min.	max		min.	max		min.	max		min.	max		min.	max	
	in. mm	in. mm	in. mm	in. mm	in. mm	in. mm	in. mm	in. mm	in. mm	in. mm	in. mm	in. mm	in. mm	in. mm	in. mm	in. mm	in. mm	in. mm	in. mm
315 400	-16	-18	-4	18T 12L	-22	0	22T 16L	-24	-10	24T 6L	-29	-6	29T 10L	-34	-20	34T 4T	-39	-16	39T 0T
	-40	-46	-10	46T 30L	-57	0	57T 40L	-62	-26	62T 14L	-73	-16	73T 24L	-87	-51	87T 11T	-98	-41	98T 1T
400 500	-18	-20	-4	20T 14L	-25	0	25T 18L	-26	-11	26T 7L	-31	-7	31T 11L	-37	-22	37T 4T	-43	-18	43T 0T
	-45	-50	-10	50T 35L	-63	0	63T 45L	-67	-27	67T 18L	-80	-17	80T 28L	-95	-55	95T 10T	-108	-45	108T 0T
500 630	-20	-28	-10	28T 10L	-38	-10	38T 10L	-35	-17	35T 3L	-45	-17	45T 3L	-48	-31	48T 11T	-58	-31	58T 11T
	-50	-70	-26	70T 24L	-96	-26	96T 24L	-88	-44	88T 6L	-114	-44	114T 6L	-122	-78	122T 28T	-148	-78	148T 28T
630 800	-30	-31	-12	31T 18L	-43	-12	43T 18L	-39	-20	39T 10L	-51	-20	51T 10L	-54	-35	54T 5T	-66	-35	66T 5T
	-75	-80	-30	80T 45L	-110	-30	110T 45L	-100	-50	100T 25L	-130	-50	130T 25L	-138	-88	138T 13T	-168	-88	168T 13T
800 1000	-39	-35	-13	35T 26L	-49	-13	49T 26L	-44	-22	44T 17L	-57	-22	57T 17L	-61	-39	61T 0T	-75	-39	75T 0T
	-100	-90	-34	90T 66L	-124	-34	124T 66L	-112	-56	112T 44L	-146	-56	146T 44L	-156	-100	156T 0T	-190	-100	190T 0T
1000 1250	-49	-42	-16	42T 33L	-57	-16	57T 33L	-52	-26	52T 23L	-67	-26	67T 23L	-73	-47	73T 2L	-89	-47	89T 2L
	-125	-106	-40	106T 85L	-145	-40	145T 85L	-132	-66	132T 59L	-171	-66	171T 59L	-186	-120	186T 5L	-225	-120	225T 5L
1250 1600	-63	-50	-19	50T 44L	-68	-19	68T 44L	-61	-31	61T 32L	-80	-31	80T 23L	-86	-55	86T 8L	-104	-55	104T 8L
	-160	-126	-48	126T 112L	-173	-48	173T 112L	-156	-78	156T 82L	-203	-78	203T 82L	-218	-140	218T 20L	-265	-140	265T 20L
1600 2000	-79	-59	-23	59T 56L	-82	-23	82T 56L	-72	-36	72T 43L	-95	-36	95T 43L	-103	-67	103T 12L	-126	-67	126T 12L
	-200	-150	-58	150T 142L	-208	-58	208T 142L	-184	-92	184T 108L	-242	-92	242T 108L	-262	-170	262T 30L	-320	-170	320T 30L
2000 2500	-98	-70	-27	70T 71L	-96	-27	96T 71L	-87	-43	87T 55L	-112	-43	112T 55L	-120	-77	120T 21L	-146	-77	146T 21L
	-250	-178	-68	178T 182L	-243	-68	243T 182L	-220	-110	220T 140L	-285	-110	285T 140L	-305	-195	305T 55L	-370	-195	370T 55L

The tolerances in this table are in conformance with ANSI/ABMA Standard 7 – 1988.

FAFNIR RADIAL BALL BEARINGS

ABEC-1 AND ABEC-3 BALL BEARINGS

Shaft and Housing Fits

The tables on the following pages show information supplemental to and coherent with that found on pages 17 through 25 as applied to ball bearings. Actual shaft and housing diameters are listed for ABEC-1, ABEC-3 and angular contact 7000WN series. These recommendations can be used for most applications having light to normal loads. Shaft and housing fits for wide inner ring ball bearings are found on page 44.

ABEC-7 BALL BEARINGS

Shaft fits;

As a general rule, it is recommended that the shaft size and tolerance for seating ABEC-7 superprecision bearings be the same as the bearing bore thus producing an average line-to-line fit. For larger shaft sizes the average fit increases to a slight interference.

Example:

Bore Size, Inches	Shaft Diameter, Inches	Resultant Mounting Fits, Inches	Average Fit
max. 2.1654	min. 2.1652	.0002 tight	line-to-line
min. 2.1652	max. 2.1654	.0002 loose	

Housing fits;

Under normal conditions of rotating shaft, the outer ring is stationary and should be mounted with a hand push or light tapping fit. Should the housing be the rotating member, the same fundamental considerations apply in mounting the outer race as in the case of an inner ring mounted on a rotating shaft.

As a general rule, the minimum housing bore dimensions for superprecision bearings may be established as the same as the maximum bearing outside diameter. If the bearing O.D. tolerance is .0003 inch, the maximum housing bore should be established as .0003 inch larger than the minimum housing bore dimension.

Example:

Outside Diameter, Inches	Housing Bore, Inches	Resultant Mounting Fits, Inches	Average Fit, Inches
max. 3.5433	min. 3.5433	.0000 tight	.0003 loose
min. 3.5430	max. 3.5436	.0006 loose	

On high-speed applications, it is extremely important that the floating bearing or pair can move axially to compensate for thermal changes. It cannot float laterally if restricted by a tight housing bore or by the radial expansion of the bearing itself. Cases involving unusual conditions should be submitted to Timken Engineering for complete recommendations.

It is equally important that all shaft and housing shoulders be absolutely square, and that the faces of the spacers be square and parallel.

SELECTIVE ASSEMBLY

Under certain conditions it may be desirable to control fits more accurately without the added expense of using closer-tolerance bearings and mating parts. This can be accomplished by selective assembly of bearings, shafts and housings after they have been sized and grouped according to bores and outside diameters. Generally, however, it is more satisfactory for production and servicing to use closer shaft and housing tolerances with bearings having a higher degree of precision.

Bearings with coded bores and O.D.'s are available on special order to facilitate this selective assembly process.

SHAFTS AND HOUSING FILLETS

The recommended shaft and housing fillet radii listed in the dimension tables of the product catalogs should be used to assure proper seating of the bearings against shaft and housing shoulders. The manufacturing tolerances on bearing corner radii are such that the corners will clear the cataloged fillet radii when the bearings are tightly seated against shoulders. Shaft and housing radii and shoulders should be free from nicks and burrs. Whenever possible, undercutting of bearing seats and adjacent shoulders per figure below is advisable to help avoid tapered bearing seats, and assure clearing corners.

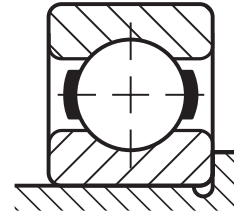

FINISH OF SHAFTS AND HOUSINGS

For ABEC-1 bearing applications shaft finish should be 32 micro inches AA maximum regardless of size.

These figures are to be used as a guide only. Special situations may demand better finishes.

FAFNIR RADIAL BALL BEARING

SHAFT FITS, ABEC-1, ABEC-3

NOTE: These tables are to be used for applications where only one ring (either inner or outer) has an interference fit with its shaft and housing. The guidelines for operating conditions covering these tables are found on page 32. In cases where interference fits are used for both rings, bearings with a special internal clearance may be required. Shaft diameter dimensions are for solid steel shafts. Consult The Timken Company when using hollow shafts.

SHAFT FITS, ABEC-1, ABEC-3					These diameters result in shaft to bearing bore fit which closely conforms to k5 listed on pages 18 and 20.							These diameters result in shaft to bearing bore fit which closely conforms to g6 listed on pages 18 and 20.								
					Shaft Rotating, Load Stationary or Shaft Stationary, Load Rotating				Shaft Stationary, Load Stationary or Shaft Rotating, Load Rotating											
Basic Bearing Number	Bore Tolerance				shaft diameter				mean fit tight ABEC-1 ABEC-3				shaft diameter				mean fit loose ABEC-1 ABEC-3			
	max.	min.			max.	min.		ABEC-1		ABEC-3		max.	min.		ABEC-1		ABEC-3			
	in.	mm	in.	mm	in.	mm	in.	mm	in.	mm	in.	mm	in.	mm	in.	mm	in.	mm		
EXTRA-SMALL 30, S, F-FLANGED SERIES																				
33K3, F33K3	0.1250	3.175	0.1247	3.167	0.1252	3.180	0.1250	3.175	0.00025	0.006	0.00020	0.005	0.1248	3.170	0.1245	3.162	0.00020	0.005	0.00025	0.006
33K4	0.1250	3.175	0.1247	3.167	0.1252	3.180	0.1250	3.175	0.00025	0.006	0.00020	0.005	0.1248	3.170	0.1245	3.162	0.00020	0.005	0.00025	0.006
33K5	0.1875	4.762	0.1872	3.754	0.1877	4.768	0.1875	4.762	0.00025	0.006	0.00020	0.005	0.1873	4.752	0.1870	4.750	0.00020	0.005	0.00025	0.006
34K	0.1575	4.000	0.1572	3.992	0.1577	4.006	0.1575	4.001	0.00025	0.006	0.00020	0.005	0.1573	3.995	0.1570	3.988	0.00020	0.005	0.00025	0.006
35K	0.1969	5.000	0.1966	4.992	0.1971	5.006	0.1969	5.001	0.00025	0.006	0.00020	0.005	0.1967	4.996	0.1964	4.989	0.00020	0.005	0.00025	0.006
36K	0.2362	6.000	0.2359	5.992	0.2364	6.005	0.2362	5.999	0.00025	0.006	0.00020	0.005	0.2360	5.994	0.2357	5.987	0.00020	0.005	0.00025	0.006
37K	0.2756	7.000	0.2753	6.992	0.2758	7.005	0.2755	6.998	0.00020	0.005	0.00015	0.004	0.2754	6.995	0.2750	6.985	0.00025	0.006	0.00030	0.008
38K,38KV	0.3150	8.000	0.3147	7.992	0.3152	8.006	0.3149	7.998	0.00020	0.005	0.00015	0.004	0.3148	7.996	0.3144	7.986	0.00025	0.006	0.00030	0.008
39K	0.3543	9.000	0.3540	8.992	0.3545	9.004	0.3542	8.997	0.00020	0.005	0.00015	0.004	0.3541	8.994	0.3537	8.984	0.00025	0.006	0.00030	0.008
S1K,S1K7,FS1K7	0.2500	6.350	0.2497	6.342	0.2502	6.355	0.2499	6.347	0.00020	0.005	0.00015	0.004	0.2498	6.345	0.2494	6.335	0.00025	0.006	0.00030	0.008
S3K,FS3K	0.3750	9.525	0.3747	9.517	0.3752	9.530	0.3749	9.522	0.00020	0.005	0.00015	0.004	0.3748	9.520	0.3744	9.510	0.00025	0.006	0.00030	0.008
S5K	0.5000	12.700	0.4997	12.692	0.5002	12.705	0.4999	12.697	0.00020	0.005	0.00015	0.004	0.4998	12.695	0.4993	12.682	0.00030	0.008	0.00035	0.009
S7K	0.6250	15.875	0.6247	15.867	0.6252	15.880	0.6249	15.872	0.00020	0.005	0.00015	0.004	0.6248	15.870	0.6243	15.857	0.00030	0.008	0.00035	0.009
S8K	0.7500	19.050	0.7496	19.040	0.7504	19.060	0.7501	19.053	0.00045	0.011	0.00035	0.009	0.7497	19.042	0.7492	19.030	0.00035	0.009	0.00045	0.011
S9K	0.8750	22.225	0.8746	22.215	0.8754	22.235	0.8751	22.228	0.00045	0.011	0.00035	0.009	0.8747	22.217	0.8742	22.205	0.00035	0.009	0.00045	0.011
S10K	1.0000	25.400	0.9996	25.390	1.0004	25.410	1.0001	25.403	0.00045	0.011	0.00035	0.009	0.9997	25.392	0.9992	25.380	0.00035	0.009	0.00045	0.011
S11K	1.1250	28.575	1.1246	28.565	1.1254	28.585	1.1251	28.578	0.00045	0.011	0.00035	0.009	1.1247	28.567	1.1242	28.555	0.00035	0.009	0.00045	0.011
S12K	1.2500	31.750	1.2495	31.737	1.2505	31.763	1.2501	31.753	0.00055	0.014	0.00045	0.011	1.2496	31.740	1.2490	31.725	0.00045	0.011	0.00055	0.014
F2DD-2	0.1253	3.183	0.1250	3.175	0.1250	3.175	0.1247	3.167	0.00030	0.008	0.00025	0.006	0.1250	3.175	0.1247	3.167	0.00030	0.008	0.00025	0.006
F2	0.1878	4.770	0.1875	4.762	0.1875	4.762	0.1872	4.755	0.00030	0.008	0.00025	0.006	0.1875	4.762	0.1872	4.755	0.00030	0.008	0.00025	0.006
F3	0.1878	4.770	0.1875	4.762	0.1875	4.762	0.1872	4.755	0.00030	0.008	0.00025	0.006	0.1875	4.762	0.1872	4.755	0.00030	0.008	0.00025	0.006
F4	0.2503	6.358	0.2500	6.350	0.2500	6.350	0.2497	6.342	0.00030	0.008	0.00025	0.006	0.2500	6.350	0.2497	6.342	0.00030	0.008	0.00025	0.006
F5	0.3128	7.946	0.3125	7.938	0.3125	7.938	0.3122	7.930	0.00030	0.008	0.00025	0.006	0.3125	7.938	0.3122	7.930	0.00030	0.008	0.00025	0.006

⁰⁾Mean fit loose. These sizes have plus bore tolerances.

SHAFT AND HOUSING FITS

FAFNIR RADIAL BALL BEARING

SHAFT FITS, ABEC-1, ABEC-3

NOTE: These tables are to be used for applications where only one ring (either inner or outer) has an interference fit with its shaft and housing. The guidelines for operating conditions covering these tables are found on page 32. In cases where interference fits are used for both rings, bearings with a special internal clearance may be required. Shaft diameter dimensions are for solid steel shafts. Consult The Timken Company when using hollow shafts.

SHAFT FITS, ABEC-1, ABEC-3		These diameters result in shaft to bearing bore fit which closely conforms to k5 listed on pages 18 and 20.								These diameters result in shaft to bearing bore fit which closely conforms to g6 listed on pages 18 and 20.											
		Basic Bearing Number		Bore Tolerance		Shaft Rotating, Load Stationary or Shaft Stationary, Load Rotating				Shaft Stationary, Load Stationary or Shaft Rotating, Load Rotating											
		max.		min.		shaft diameter		mean fit tight		shaft diameter		mean fit loose									
		in.	mm	in.	mm	in.	mm	in.	mm	in.	mm	in.	mm	in.	mm						
9100, 9300, 200, 300, 5200, 5300 SERIES																					
00		0.3937	10	0.3934	9.992	0.3939	10.005	0.3936	9.997	0.0002	0.005	0.00015	0.004	0.3935	9.995	0.3931	9.985	0.00025	0.006	0.00030	0.008
01		0.4724	12	0.4721	11.992	0.4726	12.004	0.4723	11.996	0.0002	0.005	0.00015	0.004	0.4722	11.994	0.4717	11.981	0.00030	0.008	0.00035	0.009
02		0.5906	15	0.5903	14.992	0.5908	15.006	0.5905	14.999	0.0002	0.005	0.00015	0.004	0.5904	14.996	0.5899	14.983	0.00030	0.008	0.00035	0.009
03		0.6693	17	0.6690	16.992	0.6695	17.005	0.6692	16.998	0.0002	0.005	0.00015	0.004	0.6691	16.995	0.6686	16.982	0.00030	0.008	0.00035	0.009
04		0.7874	20	0.7870	19.990	0.7879	20.010	0.7875	20.002	0.0005	0.013	0.00035	0.009	0.7871	19.992	0.7866	19.980	0.00035	0.009	0.00045	0.011
05		0.9843	25	0.9839	24.990	0.9848	25.014	0.9844	25.004	0.0005	0.013	0.00035	0.009	0.9840	24.994	0.9835	24.981	0.00035	0.009	0.00045	0.011
06		1.1811	30	1.1807	29.990	1.1816	30.010	1.1812	30.002	0.0005	0.013	0.00035	0.009	1.1808	29.992	1.1803	29.980	0.00035	0.009	0.00045	0.011
07		1.378	35	1.3775	34.987	1.3785	35.014	1.3781	35.004	0.0006	0.014	0.00045	0.011	1.3776	34.991	1.3770	34.976	0.00045	0.011	0.00055	0.014
08		1.5748	40	1.5743	39.987	1.5753	40.013	1.5749	40.002	0.0006	0.014	0.00045	0.011	1.5744	39.990	1.5738	39.975	0.00045	0.011	0.00055	0.014
09		1.7717	45	1.7712	44.987	1.7722	45.014	1.7718	45.004	0.0006	0.014	0.00045	0.011	1.7713	44.991	1.7707	44.976	0.00045	0.011	0.00055	0.014
10		1.9685	50	1.9680	49.987	1.9690	50.013	1.9686	50.002	0.0006	0.014	0.00045	0.011	1.9681	49.990	1.9675	49.974	0.00045	0.011	0.00055	0.014
11		2.1654	55	2.1648	54.985	2.1660	55.016	2.1655	55.004	0.0007	0.017	0.00055	0.014	2.1650	54.991	2.1643	54.973	0.00045	0.011	0.00055	0.014
12		2.3622	60	2.3616	59.985	2.3628	60.015	2.3623	60.002	0.0007	0.017	0.00055	0.014	2.3618	59.990	2.3611	59.972	0.00045	0.011	0.00055	0.014
13		2.5591	65	2.5585	64.985	2.5597	65.016	2.5592	65.004	0.0007	0.017	0.00055	0.014	2.5587	64.991	2.5580	64.973	0.00045	0.011	0.00055	0.014
14		2.7559	70	2.7553	69.985	2.7565	70.015	2.7560	70.002	0.0007	0.017	0.00055	0.014	2.7555	69.990	2.7548	69.972	0.00045	0.011	0.00055	0.014
15		2.9528	75	2.9522	74.985	2.9534	75.016	2.9529	75.004	0.0007	0.017	0.00055	0.014	2.9524	74.991	2.9517	74.973	0.00045	0.011	0.00055	0.014
16		3.1496	80	3.1490	79.985	3.1502	80.015	3.1497	80.002	0.0007	0.017	0.00055	0.014	3.1492	79.990	3.1485	79.972	0.00045	0.011	0.00055	0.014
17		3.3465	85	3.3457	84.980	3.3472	85.019	3.3466	85.004	0.0008	0.020	0.00065	0.017	3.3460	84.988	3.3452	84.968	0.00050	0.013	0.00065	0.017
18		3.5433	90	3.5425	89.980	3.5440	90.018	3.5434	90.002	0.0008	0.020	0.00065	0.017	3.5428	89.987	3.5420	89.967	0.00050	0.013	0.00065	0.017
19		3.7402	95	3.7394	94.980	3.7409	95.019	3.7403	95.004	0.0008	0.020	0.00065	0.017	3.7397	94.988	3.7389	94.968	0.00050	0.013	0.00065	0.017
20		3.9370	100	3.9362	99.980	3.9377	100.018	3.9371	100.002	0.0008	0.020	0.00065	0.017	3.9365	99.987	3.9357	99.967	0.00050	0.013	0.00065	0.017
21		4.1339	105	4.1331	104.980	4.1346	105.019	4.1340	105.004	0.0008	0.020	0.00065	0.017	4.1334	104.988	4.1326	104.968	0.00050	0.013	0.00065	0.017
22		4.3307	110	4.3299	109.980	4.3314	110.018	4.3308	110.002	0.0008	0.020	0.00065	0.017	4.3302	109.987	4.3294	109.967	0.00050	0.013	0.00065	0.017
EXTRA-LARGE SERIES																					
124, 224, 324		4.7244	120	4.7236	119.980	4.7251	120.018	4.7245	120.002	0.0008	0.020	0.00065	0.017	4.7239	119.987	4.7231	119.967	0.00050	0.013	0.00065	0.017
126, 226, 326		5.1181	130	5.1171	129.975	5.1189	130.020	5.1182	130.002	0.0010	0.024	0.00075	0.019	5.1175	129.984	5.1166	129.962	0.00055	0.014	0.00075	0.019
128, 228, 328		5.5118	140	5.5108	139.975	5.5126	140.020	5.5119	140.002	0.0010	0.024	0.00075	0.019	5.5112	139.984	5.5103	139.962	0.00055	0.014	0.00075	0.019
9130, 130, 230, 330		8.6614	220	8.6602	219.969	8.6624	220.025	8.6616	220.005	0.0012	0.030	0.00085	0.023	8.6608	219.984	8.6596	219.954	0.00060	0.015	0.00085	0.023
9132, 132, 232		6.2992	160	6.2982	159.975	6.3000	160.020	6.2993	160.002	0.0010	0.024	0.00075	0.019	6.2986	159.984	6.2977	159.962	0.00055	0.014	0.00075	0.019
9134, 134, 234		6.6929	170	6.6919	169.975	6.6937	170.020	6.6930	170.002	0.0010	0.024	0.00075	0.019	6.6923	169.984	6.6914	169.962	0.00055	0.014	0.00075	0.019
9136, 136, 236, 336		7.0866	180	7.0856	179.975	7.0874	180.020	7.0867	180.002	0.0010	0.024	0.00075	0.019	7.0860	179.984	7.0851	179.962	0.00055	0.014	0.00075	0.019
9138, 138, 238, 338		7.4803	190	7.4791	189.970	7.4813	190.025	7.4805	190.005	0.0012	0.030	0.00095	0.024	7.4797	189.984	7.4786	189.956	0.00055	0.014	0.00080	0.020
9140, 240, 340		7.8740	200	7.8728	199.969	7.8750	200.025	7.8742	200.005	0.0012	0.030	0.00085	0.023	7.8734	199.984	7.8722	199.954	0.00060	0.015	0.00085	0.023
9142, 240, 340		8.2677	210	8.2665	212.509	8.2687	213.020	8.2678	213.000	0.0012	0.030	0.00085	0.023	8.2670	212.509	8.2658	212.509	0.00060	0.015	0.00085	0.023
9144, 244, 344		8.6614	220	8.6602	219.969	8.6624	220.025	8.6616	220.005	0.0012	0.030	0.00085	0.023	8.6608	219.984	8.6596	219.954	0.00060	0.015	0.00085	0.023
9146, 246		9.0551	230	9.0539	229.969	9.0561	230.025	9.0553	230.005	0.0012	0.030	0.00085	0.023	9.0545	230.022	9.0533	229.951	0.00060	0.015	0.00085	0.023
248, 348		9.4488	240	9.4476	239.969	9.4498	240.025	9.4490	240.005	0.0012	0.030	0.00085	0.023	9.4482	239.984	9.4470	239.954	0.00060	0.015	0.00085	0.023
250		9.8425	250	9.8411	249.964	9.8434	250.020	9.8426	250.005	0.0012	0.030	0.00085	0.023	9.8418	250.022	9.8406	249.972	0.00060	0.015	0.00085	0.023
9152, 252, 352		10.2362	260	10.2348	259.964	10.2373	260.027	10.2364	260.005	0.0014	0.036	0.0010	0.027	10.2355	259.982	10.2343	259.951	0.00060	0.015	0.00085	0.023
9156, 256, 356		11.0236	280	11.0222	279.964	11.0247	280.027	11.0238	280.005	0.0014	0.036	0.0010	0.027	11.0229	279.982	11.0217	279.951	0.00060	0.015	0.00085	0.023
9160, 260		11.8110	300	11.8096	299.964	11.8121	300.027	11.8112	300.005	0.0014	0.036	0.0010	0.027	11.8103	299.982	11.8091	299.951	0.00060	0.015	0.00085	0.023
9164, 264		12.5984	320	12.5970	319.964	12.5996	320.030	12.5986	320.005	0.0015	0.038	0.0010	0.027	12.5977	319.982	12.5963	319.946	0.00060	0.015	0.00085	0.023
9180		15.7480	400	15.7464	399.969	15.7492	400.030	15.7482	400.005	0.0015	0.038	0.0010	0.027	15.7473	399.982	15.7459	399.946	0.00060	0.015	0.00085	0.023

FAFNIR RADIAL BALL BEARING

SHAFT FITS, 7000 WN

NOTE: These tables are to be used for applications where only one ring (either inner or outer) has an interference fit with its shaft and housing. The guidelines for operating conditions covering these tables are found on page 32. In cases where interference fits are used for both rings, bearings with a special internal clearance may be required. Shaft diameter dimensions are for solid steel shafts. Consult The Timken Company when using hollow shafts.

SHAFT FITS, 7000 WN Single Row Angular Contact Bearings					These diameters result in shaft to bearing bore fit which closely conforms to j5 listed on pages 18 and 20.				Mean Tight Fit	
					Shaft Rotating, Load Stationary shaft diameter					
Bearing Bore Number	Bearing Bore Diameter				max.				min.	
	max.	min.	max.	min.	max.	min.	max.	min.	max.	min.
	in.	mm	in.	mm	in.	mm	in.	mm	in.	mm
00	0.3937	10	0.3934	9.992	0.3936	9.997	0.3939	10.005	0.0002	0.005
01	0.4724	12	0.4721	11.991	0.4723	11.996	0.4726	12.004	0.0002	0.005
02	0.5906	15	0.5903	14.994	0.5905	14.999	0.5908	15.006	0.0002	0.005
03	0.6693	17	0.6690	16.993	0.6692	16.998	0.6695	17.005	0.0002	0.005
04	0.7874	20	0.7871	19.992	0.7873	19.997	0.7876	20.005	0.0002	0.005
05	0.9843	25	0.9840	24.994	0.9842	24.999	0.9845	25.006	0.0002	0.005
06	1.1811	30	1.1808	29.992	1.1810	29.997	1.1813	30.005	0.0002	0.005
07	1.3780	35	1.3777	34.994	1.3779	34.999	1.3783	35.009	0.00025	0.006
08	1.5748	40	1.5745	39.992	1.5747	39.997	1.5751	40.008	0.00025	0.006
09	1.7717	45	1.7714	44.994	1.7716	44.999	1.7720	45.009	0.00025	0.006
10	1.9685	50	1.9682	49.992	1.9684	49.997	1.9688	50.008	0.00025	0.006
11	2.1654	55	2.1650	54.991	2.1653	54.999	2.1658	55.011	0.00035	0.009
12	2.3622	60	2.3618	59.990	2.3621	59.997	2.3626	60.010	0.00035	0.009
13	2.5591	65	2.5587	64.991	2.5590	64.999	2.5595	65.011	0.00035	0.009
14	2.7559	70	2.7555	69.990	2.7558	69.997	2.7563	70.010	0.00035	0.009
15	2.9528	75	2.9524	74.991	2.9527	74.999	2.9532	75.011	0.00035	0.009
16	3.1496	80	3.1492	79.990	3.1495	79.997	3.1500	80.010	0.00035	0.009
17	3.3465	85	3.3460	84.988	3.3464	84.999	3.3470	85.014	0.00045	0.011
18	3.5433	90	3.5428	89.987	3.5432	89.997	3.5438	90.013	0.00045	0.011
19	3.7402	95	3.7397	94.988	3.7401	94.999	3.7407	95.014	0.00045	0.011
20	3.9370	100	3.9365	99.987	3.9369	99.997	3.9375	100.013	0.00045	0.011
21	4.1339	105	4.1334	104.988	4.1338	104.999	4.1344	105.014	0.00045	0.011
22	4.3307	110	4.3302	109.987	4.3306	109.997	4.3312	110.012	0.00045	0.011
24	4.7244	120	4.7239	119.987	4.7243	119.997	4.7249	120.012	0.00045	0.011
26	5.1181	130	5.1174	129.982	5.1180	129.997	5.1187	130.015	0.0006	0.015
28	5.5118	140	5.5111	139.982	5.5117	139.997	5.5124	140.015	0.0006	0.015
30	5.9055	150	5.9048	149.982	5.9054	149.997	5.9061	150.015	0.0006	0.015

FAFNIR RADIAL BALL BEARING

HOUSING FITS, ABEC-1, ABEC-3

NOTE: These tables are to be used for applications where only one ring (either inner or outer) has an interference fit with its shaft and housing. The guidelines for operating conditions covering these tables are found on page 32. In cases where interference fits are used for both rings, bearings with a special internal clearance may be required. Shaft diameter dimensions are for solid steel shafts. Consult The Timken Company when using hollow shafts.

HOUSING FITS, ABEC-1, ABEC-3						These diameters result in a bearing O.D. to to housing bore fit which closely conforms to H6 listed on pages 22 and 24.				These diameters result in a bearing O.D. housing bore fit which closely conforms to M7 listed on pages 23 and 25.					
						Housing Stationary, Load Stationary or Housing Rotating, Load Rotating				Housing Stationary, Load Stationary or Housing Rotating, Load Rotating					
Basic Bearing Number						Housing Bore				Housing Bore					
Extra Small	Extra Light	Light	Medium	Heavy		minimum	maximum	Mean Fit	Loose	minimum	maximum	Mean Fit	Tight	ABEC-3	
30, S, F SERIES						in.	mm	in.	mm	in.	mm	in.	mm	in.	mm
9100, 9300	200, 7200	300, 7300	7400			0.3750	9.525	0.3754	9.535	0.00040	0.010	0.00035	0.009	0.3743	9.507
33K3, F33K3	-	-	-	-	-	0.5000	12.700	0.5004	12.710	0.00040	0.010	0.00035	0.009	0.4993	12.682
33K4	-	-	-	-	-	0.5000	12.700	0.5004	12.710	0.00040	0.010	0.00035	0.009	0.4993	12.682
33K5, F33K5	-	-	-	-	-	0.6299	15.999	0.6303	16.010	0.00040	0.010	0.00035	0.009	0.6292	15.982
34K	-	-	-	-	-	0.7480	18.999	0.7485	19.012	0.00045	0.011	0.00040	0.010	0.7472	18.979
35K	-	-	-	-	-	0.7480	18.999	0.7485	19.012	0.00045	0.011	0.00040	0.010	0.7472	18.979
36K	-	-	-	-	-	0.8661	21.999	0.8666	22.012	0.00045	0.011	0.00040	0.010	0.8653	21.979
37K	-	-	-	-	-	0.8661	21.999	0.8666	22.012	0.00045	0.011	0.00040	0.010	0.8653	21.979
38K	-	-	-	-	-	0.9449	24.000	0.9454	24.013	0.00045	0.011	0.00040	0.010	0.9441	23.980
38KV	-	-	-	-	-	1.0236	25.999	1.0241	26.012	0.00045	0.011	0.00040	0.010	1.0228	25.979
39K	9100	-	-	-	-	0.6250	15.875	0.6254	15.885	0.00040	0.010	0.00035	0.009	0.6243	15.857
S1K7, FS1K7	-	-	-	-	-	0.7500	19.050	0.7505	19.063	0.00045	0.011	0.00040	0.010	0.7492	19.030
S1K	-	-	-	-	-	0.8750	22.225	0.8755	22.238	0.00045	0.011	0.00040	0.010	0.8742	22.205
S3K, FS3K	-	-	-	-	-	1.1250	28.575	1.1255	28.588	0.00045	0.011	0.00040	0.010	1.1242	28.555
S5K	-	-	-	-	-	1.3750	34.925	1.3756	34.940	0.00055	0.014	0.00045	0.011	1.3740	34.900
S7K	-	-	-	-	-	1.6250	41.275	1.6256	41.290	0.00055	0.014	0.00045	0.011	1.6240	41.250
S8K	-	-	-	-	-	1.8750	47.625	1.8756	47.640	0.00055	0.014	0.00045	0.011	1.8740	47.600
S9K	-	-	-	-	-	2.0000	50.800	2.0007	50.818	0.00060	0.015	0.00055	0.014	1.9988	50.770
S10K	-	-	-	-	-	2.1250	53.975	2.1257	53.993	0.00060	0.015	0.00055	0.014	2.1238	53.945
S11K	-	-	-	-	-	2.2500	57.150	2.2507	57.168	0.00060	0.015	0.00055	0.014	2.2488	57.120
S12K	-	-	-	-	-	0.3750	9.525	0.3753	9.533	0.00000	0.000	0.00000	0.000	0.3749	9.522
F2002	-	-	-	-	-	0.4375	11.112	0.4378	11.120	0.00000	0.000	0.00000	0.000	0.4374	11.110
F2	-	-	-	-	-	0.5624	14.285	0.5628	14.295	0.00000	0.000	0.00000	0.000	0.5624	14.285
F3	-	-	-	-	-	0.6249	15.872	0.6253	15.883	0.00000	0.000	0.00000	0.000	0.6249	15.872
F4	-	-	-	-	-	0.6874	17.460	0.6878	17.470	0.00000	0.000	0.00000	0.000	0.6874	17.460
F5	-	-	-	-	-	1.1024	28.001	1.1029	28.014	0.00045	0.011	0.00040	0.010	1.1016	27.981
-	9101, 9302	-	-	-	-	1.1811	30.000	1.1816	30.013	0.00045	0.011	0.00040	0.010	1.1803	29.980
-	9303	200	-	-	-	1.2598	31.999	1.2604	32.014	0.00055	0.014	0.00045	0.011	1.2588	31.974
-	9102	201	-	-	-	1.3780	35.001	1.3786	35.016	0.00055	0.014	0.00045	0.011	1.3770	34.976
-	9103	202	300	-	-	1.4567	37.000	1.4573	37.015	0.00055	0.014	0.00045	0.011	1.4557	36.975
-	9304	-	301	-	-	1.5748	40.000	1.5754	40.015	0.00055	0.014	0.00045	0.011	1.5738	39.975
-	-	203	-	-	-	1.6535	41.999	1.6541	42.014	0.00055	0.014	0.00045	0.011	1.6525	41.974
-	9104, 9305	-	302	-	-	1.8504	47.000	1.8510	47.015	0.00055	0.014	0.00045	0.011	1.8494	46.975
-	9105, 9306	204	303	-	-	2.0472	51.999	2.0479	52.017	0.00060	0.015	0.00055	0.014	2.0460	51.968
-	-	205	304	-	-	2.1654	55.001	2.1661	55.019	0.00060	0.015	0.00055	0.014	2.1642	54.971
-	9106, 9307	-	-	-	-	2.4409	61.999	2.4416	62.017	0.00060	0.015	0.00055	0.014	2.4397	61.968
-	9107, 9308	206	305	403	-	2.6772	68.001	2.6779	68.019	0.00060	0.015	0.00055	0.014	2.6760	67.970
-	9108	-	-	-	-	2.8346	71.999	2.8353	72.017	0.00060	0.015	0.00055	0.014	2.8334	71.968
-	9310	207	306	404	-	2.9528	75.001	2.9535	75.019	0.00060	0.015	0.00055	0.014	2.9516	74.971
-	9109	-	-	-	-	3.1496	80.000	3.1503	80.018	0.00060	0.015	0.00055	0.014	3.1484	79.969
-	9110	208	307	405	-	3.3456	85.001	3.3474	85.024	0.00080	0.019	0.00065	0.017	3.3451	84.966
-	9312	209	-	-	-	3.5433	90.000	3.5442	90.023	0.00080	0.019	0.00065	0.017	3.5419	89.964
-	9111	210	308	406	-	3.7402	95.001	3.7411	120.424	0.00080	0.019	0.00065	0.017	3.7388	94.965
-	9112	-	-	-	-	3.9370	100.000	3.9379	100.023	0.00080	0.019	0.00065	0.017	3.9356	99.964
-	9113	211	309	407	-	4.3307	110.000	4.3316	110.023	0.00080	0.019	0.00065	0.017	4.3293	109.964
-	9114	212	310	408	-										

FAFNIR RADIAL BALL BEARING

HOUSING FITS, ABEC-1, ABEC-3

NOTE: These tables are to be used for applications where only one ring (either inner or outer) has an interference fit with its shaft and housing. The guidelines for operating conditions covering these tables are found on page 32. In cases where interference fits are used for both rings, bearings with a special internal clearance may be required. Shaft diameter dimensions are for solid steel shafts. Consult The Timken Company when using hollow shafts.

HOUSING FITS, ABEC-1, ABEC-3					These diameters result in a bearing O.D. to housing bore fit which closely conforms to H6 listed on pages 22 and 24.								These diameters result in a bearing O.D. to housing bore fit which closely conforms to M7 listed on pages 23 and 25.							
Basic Bearing Number					Housing Stationary, Load Stationary or Housing Rotating, Load Rotating								Housing Rotating, Load Stationary or Housing Stationary, Load Rotating							
Extra Small	Extra Light	Light	Medium	Heavy	Housing Bore				mean fit loose				Housing Bore				mean fit tight			
30,S,F SERIES	9100,9300 SERIES	200,7200 SERIES	300,7300 SERIES	7400 SERIES	minimum in.	maximum mm	minimum in.	maximum mm	ABEC-1 in.	ABEC-3 mm	minimum in.	maximum mm	ABEC-1 in.	ABEC-3 mm	minimum in.	maximum mm	ABEC-1 in.	ABEC-3 mm		
-	9115	-	-	-	4.5276	115.001	4.5285	115.024	0.0008	0.019	0.00065	0.017	4.5262	114.965	4.5276	115.001	0.0004	0.010	0.00050	0.013
-	-	213	311	409	4.7244	120.000	4.7253	120.023	0.0008	0.019	0.00065	0.017	4.7230	119.964	4.7244	120.000	0.0004	0.010	0.00050	0.013
-	-	214	-	-	4.9213	125.001	4.9223	125.026	0.0009	0.023	0.00075	0.019	4.9197	124.960	4.9213	125.001	0.0004	0.010	0.00055	0.014
-	9117	215	312	410	5.1181	130.000	5.1191	130.025	0.0009	0.023	0.00075	0.019	5.1165	129.959	5.1181	130.000	0.0004	0.010	0.00055	0.014
-	9118	216	313	411	5.5118	140.000	5.5128	140.025	0.0009	0.023	0.00075	0.019	5.5102	139.959	5.5118	140.000	0.0004	0.010	0.00055	0.014
-	9120	217	314	412	5.9055	150.000	5.9065	150.025	0.0009	0.023	0.00075	0.019	5.9039	149.959	5.9055	150.000	0.0004	0.010	0.00055	0.014
-	120-2	218	315	-	6.2992	160.000	6.3002	160.025	0.0010	0.025	0.00080	0.020	6.2976	159.959	6.2992	160.000	0.0003	0.008	0.00050	0.013
-	9121	-	-	413	6.2992	160.000	6.3002	160.025	0.0010	0.025	0.00080	0.020	6.2976	159.959	6.2992	160.000	0.0003	0.008	0.00050	0.013
-	9122	129	316	-	6.6929	170.000	6.6939	170.025	0.0010	0.025	0.00080	0.020	6.6913	169.959	6.6929	170.000	0.0003	0.008	0.00050	0.013
-	122	-	-	-	6.8898	175.000	6.8908	175.026	0.0010	0.025	0.00080	0.020	6.8882	174.960	6.8898	175.001	0.0003	0.008	0.00050	0.013
-	9124	220	317	414	7.0866	180.000	7.0876	180.025	0.0010	0.025	0.00080	0.020	7.0850	179.959	7.0866	180.000	0.0003	0.008	0.00050	0.013
-	124	221	318	415	7.4803	190.000	7.4815	190.028	0.0012	0.029	0.00090	0.023	7.4785	189.954	7.4803	190.000	0.0003	0.008	0.00055	0.014
-	9126	222	319	416	7.8740	200.000	7.8752	200.028	0.0012	0.029	0.00090	0.023	7.8722	199.954	7.8740	200.000	0.0003	0.008	0.00055	0.014
-	126	-	-	-	8.0709	205.001	8.0721	205.029	0.0012	0.029	0.00090	0.023	8.0691	204.955	8.0709	205.001	0.0003	0.008	0.00055	0.014
-	9128	-	-	-	8.2677	210.000	8.2689	210.028	0.0012	0.029	0.00090	0.023	8.2659	209.954	8.2677	210.000	0.0003	0.008	0.00055	0.014
-	-	224	320	-	8.4646	215.001	8.4658	215.029	0.0012	0.029	0.00090	0.023	8.4628	214.955	8.4646	215.001	0.0003	0.008	0.00055	0.014
-	128	-	-	-	8.6614	220.000	8.6626	220.028	0.0012	0.029	0.00090	0.023	8.6596	219.954	8.6614	220.000	0.0003	0.008	0.00055	0.014
-	9130	-	321	418	8.8583	225.001	8.8595	225.029	0.0012	0.029	0.00090	0.023	8.8565	224.955	8.8583	225.001	0.0003	0.008	0.00055	0.014
-	-	226	-	-	9.0551	230.000	9.0563	230.027	0.0012	0.029	0.00090	0.023	9.0533	229.954	9.0551	230.000	0.0003	0.008	0.00055	0.014
-	130	-	-	-	9.2520	235.001	9.2532	235.029	0.0012	0.029	0.00090	0.023	9.2502	234.955	9.2520	235.001	0.0003	0.008	0.00055	0.014
-	9132	-	322	-	9.4488	240.000	9.4506	240.027	0.0012	0.029	0.00090	0.023	9.4470	239.954	9.4488	240.000	0.0003	0.008	0.00055	0.014
-	132	228	-	-	9.8425	250.000	9.8437	250.027	0.0012	0.029	0.00090	0.023	9.8407	249.954	9.8425	250.000	0.0003	0.008	0.00055	0.014
-	9134	-	324	-	10.2362	259.999	10.2374	260.032	0.0013	0.033	0.00105	0.027	10.2342	259.942	10.2362	259.999	0.0003	0.008	0.00060	0.015
-	134	-	-	420	10.4331	265.001	10.4343	265.034	0.0013	0.033	0.00105	0.027	10.4311	264.950	10.4331	265.001	0.0003	0.008	0.00060	0.015
-	-	230	-	-	10.6299	269.999	10.6311	270.032	0.0013	0.033	0.00105	0.027	10.6279	269.949	10.6299	269.999	0.0003	0.008	0.00060	0.015
-	136,9136	-	326	-	11.0236	279.999	11.0248	280.032	0.0013	0.033	0.00105	0.027	11.0216	279.949	11.0236	279.999	0.0003	0.008	0.00060	0.015
-	9138	232	-	-	11.4173	289.999	11.4185	290.039	0.0013	0.033	0.00105	0.027	11.4153	289.949	11.4173	289.999	0.0003	0.008	0.00060	0.015
-	138	-	328	-	11.8110	299.999	11.8122	300.032	0.0013	0.033	0.00105	0.027	11.8090	299.949	11.8110	299.999	0.0003	0.008	0.00060	0.015
-	9140	234	-	-	12.2047	309.999	12.2059	310.029	0.0013	0.033	-	-	12.2027	309.949	12.2047	309.999	0.0003	0.008	-	-
-	-	236	330	-	12.5984	319.999	12.5998	320.035	0.0015	0.038	-	-	12.5962	319.943	12.5984	319.999	0.0003	0.008	-	-
-	9144	238	-	-	13.3858	339.999	13.3872	340.035	0.0015	0.038	-	-	13.3836	339.943	13.3858	339.999	0.0003	0.008	-	-
-	9146	240	-	-	14.1732	359.999	14.1746	360.035	0.0015	0.038	-	-	14.1710	359.943	14.1732	359.999	0.0003	0.008	-	-
-	-	242	336	-	14.9606	380.007	14.9620	380.035	0.0015	0.038	-	-	14.9584	379.943	14.9606	379.999	0.0003	0.008	-	-
-	9152	244	338	-	15.7480	399.999	15.7494	400.035	0.0015	0.038	-	-	15.7458	399.943	15.7480	399.999	0.0003	0.008	-	-
-	9156	246	340	-	16.5354	419.999	16.5370	420.040	0.0017	0.038	-	-	16.5329	419.936	16.5354	419.999	0.0004	0.010	-	-
-	-	248	342	-	17.3228	439.999	17.3244	440.040	0.0017	0.038	-	-	17.3203	439.936	17.3228	439.999	0.0004	0.010	-	-
-	9160	250	344	-	18.1102	459.999	18.1118	460.040	0.0017	0.038	-	-	18.1077	459.936	18.1102	459.999	0.0004	0.010	-	-
-	9164	252	-	-	18.8976	479.999	18.8992	480.040	0.0017	0.038	-	-	18.8951	479.936	18.8976	479.999	0.0004	0.010	-	-
-	-	256	348	-	19.6850	499.999	19.6866	500.040	0.0017	0.038	-	-	19.6825	499.936	19.6850	499.999	0.0004	0.010	-	-
-	-	260	352	-	21.2598	539.999	21.2615	540.042	0.0019	0.048	-	-	21.2571	539.930	21.2598	539.999	0.0004	0.010	-	-
-	-	264	356	-	22.8346	579.999	22.8363	580.042	0.0019	0.048	-	-	22.8319	579.930	22.8346	579.999	0.0004	0.010	-	-
-	9180	-	-	-	23.6220	599.999	23.6237	600.042	0.0019	0.048	-	-	23.6193	599.930	23.6220	599.999	0.0004	0.010	-	-

RADIAL BALL AND CYLINDRICAL ROLLER BEARINGS

These charts are guidelines for specifying shaft and housing fits related to particular operating conditions.

SHAFT

Ball Bearings (For all nominal diameters)			Operating Conditions	Examples	Cylindrical Roller Bearings (Except 5200 Series)						
Loads		Shaft			Loads		Shaft Diameter mm	Shaft Tolerance Symbol	Shaft Diameter inch		
Lower Load Limit	Upper Load Limit	Tolerance Symbol			Lower Load Limit	Upper Load Limit					
INNER RING STATIONARY											
0	$C_e^{(7)}$	g6	Inner ring to be easily displaced on shaft	Wheels Non-rotating shafts	0	$C^{(6)}$	All	g6	All		
0	C_e	h6	Inner ring does not need to be easily displaced	Tension pulleys	0	C	All	h6	All		
INNER RING ROTATING, OR INDETERMINATE											
0	$0.07C_e$	j6	Light loads	Electrical apparatus Machine tools Pumps Ventilators Industrial trucks	0	$0.08C$	100	140	$k6^{(4)}$	3.94	5.51
							140	320	$m6^{(5)}$	5.51	12.60
							320	500	n6	12.60	19.68
							500	–	p6	19.68	–
0.07 C_e	0.15 C_e	k5	Normal loads	Electrical motors Turbines Pumps Combustion engines Gear transmissions etc.	0.08C	a 0.18C	100	140	m6	3.94	5.51
							140	320	n6	5.51	12.60
							320	500	p6	12.60	19.68
							500	–	r6	19.68	–
0.15 C_e	C_e	m5	Heavy loads Shock loads	Rail vehicles Traction motors	0.18C	140 C	100	140	$n6^{(3)}$	3.94	5.51
							320	500	5.51	12.60	19.68
							320	500	$r6^{(3)}$	12.60	19.68
							500	–	$r7^{(3)}$	19.68	–
THRUST LOADS											
0	C_e	j6⁽⁵⁾	Pure thrust loads	All	Not recommended, consult Timken sales office.						

⁽¹⁾ For solid shaft. See pages 18, 19, 20, and 21 for numerical values.

⁽²⁾ Use j5 for accurate applications.

⁽³⁾ Bearings with greater than nominal clearance must be used.

⁽⁴⁾ Use k5 for accurate applications.

⁽⁵⁾ Use m5 for accurate applications.

⁽⁶⁾ C = Dynamic Load Rating.

⁽⁷⁾ C_e = Extended Dynamic Load Rating (Ball Bearings).

HOUSING

Operating Conditions	Examples Tolerance Symbol ⁽¹⁾	Housing Displaceable Axially	Outer Ring
OUTER RING ROTATING			
Heavy loads with thin-wall housing	Crane support wheels Wheel hubs (roller bearings) Crank bearings	P6	No
Normal to heavy loads	Wheel hubs (ball bearings) Crank bearings	N6	No
Light loads	Conveyor rollers Rope sheaves Tension pulleys	M6	No
INDETERMINATE LOAD DIRECTION			
Heavy shock loads	Electric traction motors	M7	No
Normal to heavy loads, axial displacement of outer ring not required.	Electric motors Pumps Crankshaft main bearings	K6	no, normally
Light to normal loads, axial displacement of outer ring desired.	Electric motors Pumps Crankshaft main bearings	J6	Yes, normally
OUTER RING STATIONARY			
Shock loads, temporary complete unloading	Heavy rail vehicles	J6	Yes, normally
All loads	One-piece housing	General applications Heavy rail vehicles	Easily
	Radially split housing	Transmission drives	Easily
Heat supplied through shaft	Dryer cylinders	G7	Easily

* Below this line, housing can either be one – piece or split; above this line, a split housing is not recommended.

⁽¹⁾ Cast iron steel housing. See pages 22,23, 24 and 25 for numerical values.

Where wider tolerances are permissible, P7, N7, M7, K7, J7 and H7 values may be used in place of P6, N6, M6, K6, J6, and H6 values respectively.

RADIAL SPHERICAL ROLLER BEARINGS

These charts are guidelines for specifying shaft and housing fits related to particular operating conditions.

SHAFT

	Conditions	Examples	Shaft Diameter mm	Tolerance Symbol	Remarks
BEARINGS WITH STRAIGHT BORE					
Stationary inner ring load	The inner ring to be easily displaced on the shaft	Two-bearing shaft mechanism	All diameters	s4	See table below for shaft size.
	The inner ring not to be easily displaced on the shaft	Wheel on non-rotating shaft		g6	
		Tension pulleys and rope sheaves		h6	
Rotating inner ring load or indeterminate load direction	Light and variable loads $P \leq 0.07C$	Electrical apparatus, machine tools, pumps, ventilators, industrial trucks	Over 18 100	k6 m6	In very accurate applications k5 and m5 are used instead of k6 and m6 respectively.
			Incl. 100 200		
	Normal and heavy loads $P > 0.07C$ $\leq 0.25C$	Applications in general, electrical motors, turbines, pumps, combustion engines, gear transmissions, woodworking machines	18 65	m5 m6 n6 p6 r6 r7	
			65 100		
100 140					
Very heavy loads and shock loads $P > 0.25C$	Journal boxes for locomotives and other heavy rail vehicles, traction motors	140 280	m6 n6 p6 r6 r7		
		280 500			
		500 and up			
		18 65			
BEARINGS WITH TAPERED BORE AND ADAPTER SLEEVE					
	All loads	Applications in general	All diameters		See tables for Reduction of RIC on page 10

⁽¹⁾For solid steel shaft. See tables on pages 18, 19, 20, and 21 for numerical value.

s4 FITS

A centrifugal force load produces a rotating outer ring load and a stationary inner ring load, even though the inner ring rotates. This makes it desirable to fit the outer ring tight in the housing (using a P6 fit as shown on page 24), and the inner ring loose on the shaft using an s4 fit as listed in the table. The standard W33 bearing with oil groove and oil holes can be used.

Data shown in ten-thousandths of an inch ($6=0.0006''$) or thousandths of a millimeter ($15=0.015$ mm.). See dimensional tables for nominal bore.

s4 FITS

Bore			Variance from Nominal Bore			
Over	mm	Incl.	Tolerance +0	Shaft Diameter		Fit
			in.	max.	min.	in.
			mm	in.	mm	mm
50	80		-6	-10	-14	4L
			-15	-25	-36	14L 10L 36L
80	120		-8	-13	-17	5L
			-20	-33	-43	17L 13L 43L
120	180		-10	-16	-21	6L
			-25	-41	-53	21L 15L 53L
180	250		-12	-19	-25	7L
			-30	-48	-64	25L 18L 64L

RADIAL SPHERICAL ROLLER BEARINGS

This chart is a guideline for specifying housing fits for particular operating conditions.

HOUSING

Conditions		Examples	Tolerance Symbol ⁽²⁾	Remarks	
One piece bearing housing	Rotating outer ring load	Variable load direction	Two-bearing shaft mechanism	P6	The outer ring is not displaceable axially
		Heavy loads on bearings in thin walled housings	Supporting wheels in cranes, wheel hubs, crank bearings	P7	
		Normal and heavy loads	Wheel hubs, crank bearings	N7	
		Light and variable loads	Conveyor rollers, rope sheaves, tension pulleys	M7	
	Indeterminate load direction	Heavy shock loads	Electrical traction motors	K7	The outer ring is, as a rule, not displaceable axially.
		Heavy and normal loads, axial displacement of outer ring not required	Electrical motors, pumps, crankshaft main bearings		
Split or one piece bearing housing	Stationary outer ring load	Normal and light loads, axial displacement of the outer ring desirable	Electrical motors, pumps, crankshaft main bearings	J7	The outer ring is, as a rule, displaceable axially.
		Shock loads, temporarily complete unloading	Journal boxes for rail vehicles		
	Stationary outer ring load	All loads	Bearing applications in general, journal boxes for rail vehicles	H7	The outer ring is easily displaced axially.
		Normal and light loads, loads under simple operating conditions	Line shaftings	H8	
		Heat supplied through the shaft	Dryer cylinders	G7	
One piece bearing housing	Applications requiring particular accuracy	Very accurate running and small deflections under variable loads	For main spindles in machine tools O.D. less than 125mm O.D. 125 to 250 mm O.D. over 250mm	M6 N6 P6	The outer ring is not displaceable axially
		Very accurate running under light loads and indeterminate load direction	Held bearings in high speed centrifugal force compressors	K6	The outer ring is, as a rule, not displaceable axially.
		Very accurate running, axial displacement of outer ring desirable	Floating bearings in high speed centrifugal force compressors	J6	The outer ring is easily displaced axially.

⁽²⁾ Cast iron or steel housing. For numerical values see tables on pages 22, 23,24, and 25. For housings of light metal, tolerances generally are selected which give a slightly tighter fit than those given in the table.

RADIAL TAPERED ROLLER BEARINGS

Tolerances, shaft diameters and housing bores are shown as variances from the nominal bearing dimension. All data except nominal dimensions are in ten-thousandths of an inch (5=0.0005) and thousandths of a millimeter or micrometers (5=0.005mm).

Shaft and housing data shown in inches over millimeters.

SHAFT

Bearing Bore			t1			t2			t3			t4			t5			
Nominal (min.)		Tol.	Shaft Diam.		Fit	Shaft Diam.		Fit	Shaft Diam.		Fit	Shaft Diam.		Fit	Shaft Diam.		Fit	
Over	Incl.	-0	max.	min.		max.	min.		max.	min.		max.	min.		max.	min.		
in.	in.	in.	in.	in.	in.	in.	in.	in.	in.	in.	in.	in.	in.	in.	in.	in.		
mm	mm	mm	mm	mm	mm	mm	mm	mm	mm	mm	mm	mm	mm	mm	mm	mm		
7.5000	12.0000	+10	+25	+15	5T	—	—	+10	+0	+10L	0	-10	0L	-2	-12	2L	For Class 2 or Class 4 bearings	
190.500	304.800	+25	+64	+38	+13T			+25	0	25L	0	-25	0L	-5	-30	5L		
					64T			25T			51L			56L				
					5T			10T			20L			22L				
12.0000	24.0000	+20	+50	+30	+10T	—	—	+20	+0	20L	0	-20	0L	—	—	—		
304.800	609.600	+51	+127	+76	+25T			+51	+0	+51L	0	-51	0L					
					50T			20T			40L							
					127T			51T			102L							
24.0000	36.0000	+30	+75	+45	15T	+150	+120	90T	+30	0	30L	0	-30	0L	—	—	For Class 4 bearings only	
609.600	914.400	+76	+191	+114	38T	+381	+305	229T	+76	0	76L	0	-76	0L				
					191T			381T			76T			152L				
					15T			150T			30T			60L				

HOUSING

Bearing O.D.		Tol.	T1			T2			T3			T4			T5			
Nominal (min.)			-0	Housing Bore		Fit	Housing Bore		Fit	Housing Bore		Fit	Housing Bore		Fit	Housing Bore		
Over	Incl.	in.		in.	in.		in.	in.		in.	in.		in.	in.		in.	in.	
mm	mm	mm	mm	mm	mm	mm	mm	mm	mm	mm	mm	mm	mm	mm	mm	mm		
10.5000	12.0000	+10	+20	+30	10L	+10	+20	0L	0	+20	10T	-20	-10	10T	-30	-20	20T	For Class 2 or Class 4 bearings
266.700	304.800	+25	+51	+76	25L	+25	+51	0L	0	+51	25T	-51	-25	25T	-76	-51	51T	
					76L			51L			51L			76T			102T	
					30L			20L			20L			30T			40T	
12.0000	24.0000	+20	+40	+60	20L	+20	+40	0L	+10	+30	10T	-30	-10	10T	-40	-20	20T	
304.800	609.600	+51	+102	+152	51L	+51	+102	0L	+25	+76	25T	-76	-25	25T	-102	-51	51T	
					152L			102L			76L			127T			152T	
					60L			40L			30L			50T			60T	
24.0000	36.0000	+30	+60	+90	30L	+30	+60	0L	+20	+50	10T	-40	-10	10T	—	—	For Class 4 bearings only	
609.600	914.400	+76	+152	+114	76L	+76	+152	0L	+51	+127	25T	-102	-25	25T				
					229L			152L			127L			178T				70T
					90L			60L			50L			70T				25T

SHAFT

Shaft and housing diameter are shown in inches over millimeters with millimeters printed in red.

Mounting Conditions	Service	Shaft Finish	Shaft Diameter		Shaft Tolerance Symbol
			Over	Incl.	
Rotating Cone	Steady load moderate shock	Ground	7.5 190.5	36.0 914.0	t1
Rotating or Stationary Cone	Heavy loads, high speeds or shock	Ground or Turned	7.5 190.5	24.0 610.0	*
		Ground	24.0 610.0	36.0 914.0	t2
Stationary Cone	Moderate loads, no shock	Turned	7.5 190.5	36.0 914.0	t3
		Ground	7.5 190.5	36.0 914.0	t4
	Sheaves, wheels, etc.	Turned	7.5 190.5	36.0 914.0	t4
	Wheel spindles	Hardened	7.5 190.5	12.0 305.0	t5

HOUSING

Mounting Conditions	Service	Housing Diameter		Housing Tolerance Symbol
		Over	Incl.	
Stationary Cup	Clamped or floating (TDO) styles	10.5 266.7	36.0 914.0	T1
	Alternate clamp only (TDO, TDOC)	10.5 266.7	36.0 914.0	T2
	Adjustable	10.5 266.7	36.0 914.0	T3
Rotating Cup	Sheaves unclamped (TDOC)	10.5 266.7	24.0 160.0	T5

*Use *Turned Shaft Fitting Practice, * an average cone interference fit of 0.0005 inches (0.013mm) per inch (25.4mm) of bore diameter.

TORRINGTON THRUST BALL BEARINGS

Shaft and housing diameters shown as variance from nominal dimensions. Shaft and housing data shown in inches over millimeters.

TYPE TVB SHAFT

Bearing Bore nominal (min.)		Shaft Diameter	
Over	Incl.	Max.	Min.
in.	in.	in.	in.
mm	mm	mm	mm
0.0000	6.7500	+0	-0.0012
0.000	171.450	+0	-0.030
6.7500	20.0000	+0	-0.0015
171.450	508.000	+0	-0.038

HOUSING

Bearing O.D. nominal (max.)		Housing Bore	
Over	Incl.	Max.	Min.
in.	in.	in.	in.
mm	mm	mm	mm
4.7188	17.3750	+0.0090	+0.0050
119.858	441.325	+0.229	+0.127
17.3750	39.3701	+0.0100	+0.0060
441.325	1000.000	+0.254	+0.152

TYPE TVL AND DTVL SHAFT

Bearing Bore nominal (max.)		Shaft Diameter			
Over	Incl.	Interference Fit* Max.	Interference Fit* Min.	Loose Fit** Max.	Loose Fit** Min.
in.	in.	in.	in.	in.	in.
mm	mm	mm	mm	mm	mm
0.0000	19.8750	+0.0030	+0	-0.0060	-0.0030
0.000	504.825	+0.076	+0	-0.152	-0.076
19.8750	60.0000	+0.0050	+0	-0.0100	-0.0050
504.825	1524.000	+0.127	+0	-0.254	-0.127

* Dowel pin suggested.

** Dowel pin required.

HOUSING

Bearing O.D. nominal (min.)		Shaft Diameter			
Over	Incl.	Loose Fit** Max.	Loose Fit** Min.	Interference Fit* Max.	Interference Fit* Min.
in.	in.	in.	in.	in.	in.
mm	mm	mm	mm	mm	mm
0.0000	23.0000	+0.0060	0.0030	-0.0060	-0.0030
0.000	584.000	+0.152	0.076	-0.152	-0.076
23.0000	70.0000	+0.0100	0.0050	-0.0100	-0.0050
584.000	1778.000	+0.254	0.127	-0.254	-0.127

* Dowel pin suggested.

** Dowel pin required.

TORRINGTON THRUST CYLINDRICAL ROLLER BEARINGS

TYPE TP AND TPS SHAFT

Bearing Bore nominal (max.)		Shaft Diameter	
Over	Incl.	Max.	Min.
in.	in.	in.	in.
mm	mm	mm	mm
1.8750	2.1250	-0.0010	-0.0020
47.625	53.975	-0.025	-0.051
2.1250	2.5000	-0.0011	-0.0021
53.975	63.500	-0.028	-0.053
2.5000	3.0000	-0.0012	-0.0022
63.500	76.200	-0.030	-0.056
3.0000	3.5000	-0.0012	-0.0023
76.200	88.900	-0.033	-0.058
3.5000	7.0000	-0.0015	-0.0025
88.900	177.800	-0.038	-0.064
7.0000	9.0000	-0.0015	-0.0030
177.800	228.600	-0.038	-0.076
9.0000	12.0000	-0.0018	-0.0033
228.600	304.800	-0.046	-0.084
12.0000	15.0000	-0.0020	-0.0035
304.800	381.000	-0.051	-0.089
15.0000	19.0000	-0.0020	-0.0040
381.000	482.600	-0.051	-0.102
19.0000	23.0000	-0.0025	-0.0045
482.600	584.200	-0.064	-0.114
23.0000	30.0000	-0.0030	-0.0055
584.200	762.000	-0.076	-0.140

TYPE TP HOUSING

Bearing O.D. nominal (min.)		Housing Bore	
Over	Incl.	Max.	Min.
in.	in.	in.	in.
mm	mm	mm	mm
4.5312	10.0000	+0.0030	+0.0015
115.092	254.000	+0.076	+0.038
10.0000	18.0000	+0.0040	+0.002
254.000	457.200	+0.102	+0.051
18.0000	22.0000	+0.0050	+0.0025
457.200	558.800	+0.127	+0.064
22.0000	26.0000	+0.0055	+0.0025
558.800	660.400	+0.140	+0.064
26.0000	28.0000	+0.0060	+0.0030
660.400	711.200	+0.152	+0.076
28.0000	34.0000	+0.0070	+0.0030
711.200	863.600	+0.178	+0.076
34.0000	38.0000	+0.0080	+0.0035
863.600	965.200	+0.203	+0.089
38.0000	44.0000	+0.0090	+0.0040
965.200	1117.600	+0.229	+0.102

Note: Housing fits for Type TPS are on the following page.

TORRINGTON THRUST CYLINDRICAL ROLLER BEARINGS

Tolerances for housing bore and for shaft diameters shown as variance from nominal bearing dimension.

Data shown in inches over millimeters

TYPE TPS

HOUSING Deviations in 0.0001 inches/0.001 micrometers

Bearing O.D. nominal (min.)		Housing Diameter Deviation from D	
Over	Incl.	High	Low
in.	in.	in.	in.
mm	mm	mm	mm
2.0000	2.3750	+15	+5
50.800	60.325	+38	+13
2.3750	3.2500	+17	+7
60.325	82.550	+43	+18
3.2500	3.6875	+19	+9
82.550	93.663	+48	+23
3.6875	4.0000	+21	+11
93.663	101.600	+53	+28
4.0000	4.5312	+28	+13
101.600	115.092	+71	+33
4.5312	10.0000	+30	+15
115.092	254.000	+76	+38
10.0000	18.0000	+40	+20
254.000	457.200	+102	+51
18.0000	22.0000	+50	+25
457.200	558.800	+127	+64
22.0000	26.0000	+55	+25
558.800	660.400	+140	+64
26.0000	28.0000	+60	+30
660.400	711.200	+152	+76
28.0000	34.0000	+70	+30
711.200	863.600	+178	+76
34.0000	38.0000	+80	+35
863.600	965.200	+203	+89
38.0000	44.0000	+90	+40
965.200	1117.600	+229	+102

TORRINGTON THRUST TAPERED ROLLER BEARINGS

TYPE TTHD SHAFT

Bearing Bore nominal (min.)		Spring Loaded Max.+0 Min.	Shaft Diameter	
Over	Incl.		Rolling Mill Screwdown & Piercing Mill Thrust Blocks	
in.	in.	in.	Max.	Min.
mm	mm	mm	mm	mm
0.0000	6.8750	-0.0010	+0.0030	+0.0020
0.000	174.625	-0.025	+0.076	+0.051
6.8750	7.9999	-0.0010	+0.0040	+0.0030
174.625	203.197	-0.025	+0.102	+0.076
7.9999	12.0000	-0.0015	+0.0050	+0.0040
203.197	304.800	-0.038	+0.127	+0.102
12.0000	24.0000	-0.0020	+0.0070	+0.0050
304.800	609.600	-0.051	+0.178	+0.127
24.0000	36.0000	-0.0025	+0.0095	+0.0070
609.600	914.400	-0.064	+0.241	+0.178
36.0000	48.0000	-0.0030	+0.0120	+0.0090
914.400	1219.200	-0.076	+0.304	+0.229

TYPE TTHD HOUSING

Bearing O.D. nominal (min.)		Housing Bore	
Over	Incl.	max.	min.
in.	in.	in.	in.
mm	mm	mm	mm
6.3750	10.5000	+0.0025	+0.0010
161.925	266.700	+0.064	+0.025
10.5000	13.0000	+0.0030	+0.0010
266.700	330.200	+0.076	+0.025
13.0000	20.0000	+0.0040	+0.0020
330.200	508.000	+0.102	+0.051
20.0000	25.0000	+0.0045	+0.0020
508.000	635.000	+0.114	+0.051
25.0000	30.0000	+0.0060	+0.0030
635.000	762.000	+0.152	+0.076
30.0000	35.0000	+0.0070	+0.0030
762.000	889.000	+0.178	+0.076

TORRINGTON THRUST TAPERED ROLLER BEARINGS

Tolerances for housing bore and shaft diameters shown as variance from nominal bearing dimension.

Data shown in inches over millimeters.

When one washer is piloted by the housing, sufficient clearances

must be allowed at the outside diameter of the other washer as well as at the bore of both washers to prevent cross-threading of the rollers. For most applications, this clearance is approximately 1/16" (.0625", .1588mm).

TYPES TTV AND TTVF SHAFT

Bearing Bore nominal (min.)		Shaft Diameter Max. +O Min.
Over	Incl.	
in. mm	in. mm	in. mm
0.0000 0.000	12.0000 304.800	-0.0020 -0.051
12.0000 304.800	20.0000 508.000	-0.0020 -0.051
20.0000 508.000	28.0000 711.200	-0.0030 -0.076
28.0000 711.200	48.0000 1219.200	-0.0040 -0.102
48.0000 1219.200	68.0000 1727.200	-0.0050 -0.127

HOUSING

Bearing Bore nominal (min.)		Housing Bore	
Over	Incl.	max.	min.
in. mm	in. mm	in. mm	in. mm
6.3750 161.925	10.4375 265.113	+0.0025 +0.060	+0.0010 +0.025
10.3475 265.113	12.5000 317.500	+0.0030 +0.076	+0.0010 +0.025
12.5000 317.500	19.0000 482.600	+0.0040 +0.102	+0.0020 +0.051
19.0000 482.600	23.7500 603.250	+0.0045 +0.113	+0.0020 +0.051
23.7500 603.250	28.0000 711.200	+0.0060 +0.152	+0.0030 +0.076
28.0000 711.200	33.0000 838.200	+0.0070 +0.178	+0.0030 +0.076

TORRINGTON THRUST SPHERICAL ROLLER BEARING

Tolerances for housing bore and for shaft diameters shown as variance from nominal bearing dimension.

Data shown in inches over millimeters.

When application calls for thrust loads only, the housing must be relieved by 1/16" on diameter so that no radial load is carried on the bearing.

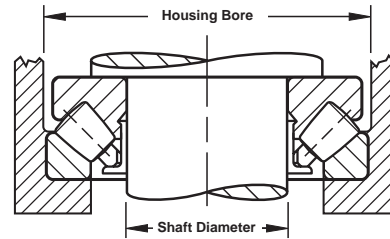

SHAFT

Tolerances are 1/10,000 of an inch (5 = .0005") and 1/1000 of a millimeter (µm)

Bearing Bore nominal (max.)		Shaft Diameter			
inches		Stationary Load		Rotating Load	
Over	Incl.	max.	min.	max.	min.
in. mm	in. mm	in. mm	in. mm	in. mm	in. mm
3.1496 80	4.7244 120	+5 +13	-4 -10	+10 +25	+1 +3
4.7244 120	7.0866 180	+6 +15	-4 -10	+11 +28	+1 +3
7.0866 180	7.8740 200	+7 +18	-5 -13	+1 +36	+2 +5
7.8740 200	9.4488 240	+7 +18	-5 -13	+18 +46	+6 +15
9.4488 240	12.4016 315	+7 +18	-6 -15	+20 +51	+8 +20
12.4016 315	15.7480 400	+7 +18	-7 -18	+22 +56	+8 +20
15.7480 400	19.6850 500	+9 +23	-7 -18	+34 +86	+18 +46
19.6850 500	24.8031 630	+9 +23	-8 -20	+34 +86	+17 +43

HOUSING

Tolerances are 1/10,000 of an inch (5 = .0005") and 1/1000 of a millimeter (µm)

Bearing O.D. nominal (max.)		Housing Bore					
inches		Springs in Housing Light Radial Load		Combined Axial & Radial Load			
Over	Incl.	min.	max.	Stationary Outer Ring		Rotating Outer Ring	
in. mm	in. mm	in. mm	in. mm	min.	max.	min.	max.
7.0866 180	9.8425 250	+6 +15	+24 +61	-7 -18	+11 +28	-13 -33	+5 +13
9.8425 250	12.4016 315	+7 +18	+27 +69	-7 -18	+13 +33	-14 -36	+6 +15
12.4016 315	15.7480 400	+7 +18	+29 +74	-7 -18	+15 +38	-16 -41	+6 +15
15.7480 400	19.6850 500	+8 +20	+33 +84	-9 -23	+16 +41	-18 -46	+7 +18
19.6850 500	24.8031 630	+9 +23	+36 +91	-9 -23	+18 +46	-19 -48	+8 +20
24.8031 630	31.4960 800	+9 +23	+40 +102	-9 -23	+20 +51	-20 -51	+9 +23
31.4960 800	39.3700 1000	+10 +25	+43 +109	-10 -25	+23 +58	-23 -58	+10 +25
39.3700 1000	49.2126 1250	+11 +28	+48 +122	-11 -28	+26 +66	-25 -64	+12 +30

Shaft and housing shoulder diameters for radial roller and thrust ball and thrust ball and roller bearings are also found in the respective dimension tables. Shaft and Housing shoulders for ball bearings are shown below.

FAFNIR RADIAL BALL BEARINGS

The preferred method of locating bearings on shafts and in housings is to provide accurate shoulders perpendicular to the shaft axis. Shoulders should be large enough to exceed the theoretical point of tangency between the corner radius and the face of the bearing, and small enough to permit bearing removal with proper pullers.

These tables give the recommended maximum and minimum shaft and housing shoulder diameters for the majority of applications. Where design limitations do not permit conformance to these recommended diameters, the Engineering department should be consulted.

Recommended shaft and housing fillet radii are listed in the dimensional tables of each product catalog and must be used to assure proper seating against shaft and housing shoulders.

Shaft and housing diameters for radial ball bearings are shown below and on the following two pages. For radial cylindrical, spherical and tapered roller bearings refer to the respective dimension tables. Housing shoulders for wide inner ring bearings are shown on page 44.

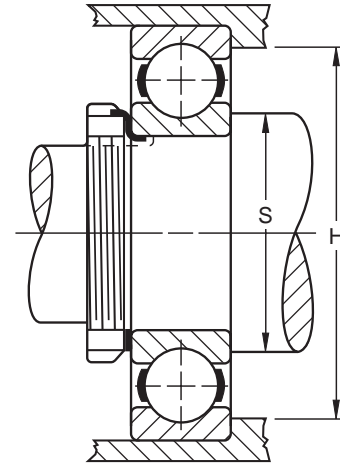

EXTRA LIGHT 9300				
Basic Bearing Number	shaft shoulder $\pm 0.10''$		housing shoulder $\pm 0.10''$	
	in.	mm	in.	mm
	9301K	0.58	14.7	0.85
9302K	0.70	17.8	1.00	25.4
9303K	0.78	19.8	1.08	27.4
9304K	0.94	23.9	1.32	33.5
9305K	1.14	29.0	1.52	38.6
9306K	1.32	33.5	1.71	43.4
9307K	1.56	39.6	2.00	50.8
9308K	1.77	45.0	2.26	57.4
9309K	1.98	50.3	2.49	63.2
9310K	2.16	54.9	2.66	67.6
9311K	2.40	61.0	2.94	74.7
9312K	2.59	65.8	3.14	79.8

EXTRA-SMALL SERIES								
Basic Bearing Number	Shoulder Diameters shaft, S				housing, H			
	max.		min.		max.		min.	
	in.	mm	in.	mm	in.	mm	in.	mm
33K3	0.20	5.1	0.19	4.8	0.32	8.1	0.31	7.9
33K4	0.24	6.1	0.23	5.8	0.44	11.2	0.43	10.9
33K5	0.26	6.6	0.25	6.4	0.44	11.2	0.43	10.9
34K	0.26	6.6	0.25	6.4	0.56	14.2	0.55	14.0
35K	0.37	9.4	0.36	9.1	0.67	17.0	0.66	16.8
36K	0.37	9.4	0.36	9.1	0.67	17.0	0.66	16.8
37K	0.44	11.2	0.42	10.7	0.79	20.1	0.77	19.6
38K	0.45	11.4	0.43	10.9	0.79	20.1	0.77	19.6
38KV	0.45	11.4	0.43	10.9	0.79	20.1	0.77	19.6
39K	0.51	13.0	0.49	12.5	0.91	23.1	0.89	22.6
S1K7	0.34	8.6	0.32	8.1	0.56	14.2	0.54	13.7
S1K	0.37	9.4	0.35	8.9	0.69	17.5	0.67	17.0
S3K	0.50	12.7	0.48	12.2	0.80	20.3	0.78	19.8
S5K	0.63	16.0	0.61	15.5	0.99	25.1	0.97	24.6
S7K	0.84	21.3	0.80	20.3	1.24	31.5	1.20	30.5
S8K	0.97	24.6	0.93	23.6	1.46	37.1	1.40	35.6
S9K	1.14	28.9	1.10	27.9	1.65	41.9	1.61	40.9
S10K	1.24	31.5	1.20	30.5	1.84	46.7	1.80	45.7
S11K	1.34	34.0	1.30	33.0	1.95	49.5	1.91	48.5
S12K	1.55	39.4	1.51	38.4	2.20	55.9	2.00	50.8

SHAFT DESIGN – TORRINGTON NEEDLE BEARINGS

When the shaft is used as the inner raceway for needle roller bearings the following specifications must be met:

1. metallurgy – either case hardening or through hardening grades of good bearing quality steel are satisfactory for raceways. Steels which are modified for free machining, such as those high in sulfur content and particularly those containing lead, are seldom satisfactory for raceways.

To realize full bearing capacity, the raceway area must be at least surface hard with a reasonable core strength. The preferred surface hardness is equivalent to 58 HRC. If the raceway is of lesser hardness, see the modification factors shown in Tables 2 and 3.

Shaft raceways for all needle roller bearings, in diameters up to 3.5 inches or 90mm should have an effective case depth of 0.030 inch or 0.8mm. (Effective case depth is defined as the distance from the surface, after final grinding, to the 50 HRC hardness level.) For raceways larger than 3.5 inches or 90 mm in diameter the effective case depth should be 0.050 inch or 1.3 mm.

2. strength – the shaft must be of sufficient size to keep the operating deflections within limits.

3. tolerance – the recommended shaft diameter tolerances for each type of needle roller bearing are indicated on the tabular pages.

4. taper – the taper within the length of the bearing raceway should not exceed 0.0003 inch (0.008 mm), or one-half the diameter tolerance, whichever is smaller.

5. out-of-roundness – the radial deviation from true circular form of the raceway should not exceed .0001 inch (0.0025mm) for diameters up to and including 1.0 inch (25mm). For raceways greater than 1.0 inch or 25mm the allowable radial deviation may be greater than .0001 inch (0.0025mm) by a factor of raceway diameter (in inches) divided by 1.0 or a factor of raceway diameter (in mm) divided by 25.

6. surface finish – the raceway finish should not exceed 8 micro-inches aa (arithmetic average) or 0,2 μm (on the Ra scale). In addition, the raceway area must be free of nicks, scratches and dents. Oil holes are permissible in the raceway area but care must be taken to blend the edges gently into the raceway.

Care must be taken to prevent grind reliefs, fillets, etc., from extending into the raceway area. If the rollers overhang a grind relief or step on the shaft, there will be high stress concentration with resultant early failure.

7. end chamfer – for most effective assembly of the shaft into a bearing, the end of the shaft should have a large chamfer or rounding. This should help in preventing damage to the roller complement, scratching of the raceway surface and nicking of the shaft end.

8. sealing surface – in some instances bearings have integral or immediately adjacent seals that operate on the surface ground for the bearing raceway. Here, particular attention should be paid to the pattern of the shaft finish. In no instance should there be a “lead”, or spiral effect, as often occurs with through feed centerless grinding. Such a “lead” may pump lubricant past the seal.

When it is undesirable or impractical to prepare the shaft to be used as a raceway, inner rings are available as listed in the tabular pages. If the shaft is not used directly as a raceway, the following design specifications must be met:

1. strength – the shaft must be of sufficient size to keep the operating deflections within limits.

2. tolerance – the recommended shaft diameter tolerances for mounting inner rings are indicated on the tabular pages.

3. taper and out-of-roundness – the taper and out-of-roundness should not exceed one-half the shaft diameter tolerance.

4. surface finish – the surface finish should not exceed 125 microinches, aa (arithmetic average) or 3.2 μm (on the Ra scale).

5. locating shoulders or steps – locating shoulders or steps in the shaft must be held to close concentricity with the bearing seat to prevent imbalance and resultant vibrations.

HOUSING DESIGN – TORRINGTON NEEDLE BEARINGS

BEARINGS WITH OUTER RINGS

For bearings with outer rings the function of the housing is to locate and support the outer ring. The following specifications must be met:

1. **strength** – housings should be designed so that the radial loads which will be placed on the bearings will cause a minimum of deflection or distortion of the housing.
2. **tolerance** – the recommended housing bore tolerances for each type of needle roller bearing are indicated on the tabular pages.
3. **taper** – the taper within the length of the outer ring should not exceed .0005 inch (0.013 mm).
4. **out-of-roundness** – the housing bore should be round within one-half the housing bore diameter tolerance.
5. **parallelism** – when possible, line bore housings which are common to one shaft to obtain parallelism of the housing bores and the shaft axis.
6. **surface finish** – the surface finish of housing bore should not exceed 125 microinches, aa (arithmetic average) or 3.2 μm (on the Ra scale).
7. **end chamfer** – to permit easy introduction of the bearing into the housing, the end of the housing should have a generous chamfer.

Heavy duty roller bearings can be installed into housings with a transition fit or a clearance fit. The outer ring should be a transition fit in the housing when it rotates relative with the load. The outer ring may be a clearance fit in the housing when it is stationary relative to the load. In either case, locate the bearings by shoulders, or other locating devices, to prevent axial movement.

Since the heavy duty roller bearing does not require an interference fit in the housing to round and size it properly, a split housing may be used if desired. Dowels should be used to maintain proper register of the housing sections.

Drawn cup bearings have a thin case-hardened outer ring which is out-of-round from the hardening operation. For proper mounting it must always be pressed into the housing. Split housing will not round and size a drawn cup bearing. When split housings must be used, the bearing should first be mounted in a cylindrical sleeve.

The housing should be of sufficient tensile strength and section to round and size the bearing. It must be designed for minimum distortion under load. Steel or cast iron housings are preferred. Housing bores in low tensile strength materials such as aluminum, magnesium, phenolics, etc., should be reduced to provide more interference fit. Thin section cast iron and steel housings may also require reduced bores. Consult The Timken Company for recommendations when working with these lower strength housings.

The housing should be through bored if possible. When shouldered housing bores are unavoidable, the bearing should be located far enough from the shoulder to avoid the danger of crushing the end of the drawn cup during installation.

When the drawn cup bearing is mounted close to the housing face, care should be taken to mount the bearing at least 0.008 inch (0.20 mm) within the housing face to protect the bearing lip.

BEARINGS WITHOUT OUTER RINGS

In many cases, such as with gear bores, it is desirable to have the housing bore serve as the outer raceway for caged needle roller assemblies or loose needle roller complements. In those instances, the following specifications must be met:

1. **strength** – the housing must be of sufficient cross section to maintain proper roundness and running clearance under the maximum load.
2. **metallurgical** – material selection, hardness and case depth should be consistent with the requirements for inner raceways given in the SHAFT DESIGN recommendations on page 40.
3. **taper and out-of-roundness** – the raceway out-of-roundness and taper should not exceed 0.0003 inch (0.008 mm) or one-half the bore tolerance, whichever is smaller. In addition, the bore diameter must never be smaller at both ends than in the center (sway-back).
4. **surface finish** – the raceway surface finish should not exceed 8 microinches, aa (arithmetic average) or 0.2 μm (on the Ra scale). In addition, the surface must be free of nicks, dents and scratches.
5. **grind reliefs** – care must be exercised to ensure that grind reliefs, fillets, etc. do not extend to the raceway. Oil holes in the raceway area are permissible but the edges must be blended smoothly with the raceway.

SHAFT AND HOUSING SHOULDERS

FAFNIR RADIAL BALL BEARINGS

Extra-Light • 9100 Series									Light • 200, 5200, 7200WN Series								Medium • 300, 5300, 7300WN Series									
Basic Bearing Number	Shoulder Diameters								Basic Bearing Number	Shoulder Diameters								Basic Bearing Number	Shoulder Diameters							
	shaft, S				housing, H					shaft, S				housing, H					shaft, S				housing, H			
	max.	min.	max.	min.	max.	min.	max.	min.		max.	min.	max.	min.	max.	min.	max.	min.		max.	min.	max.	min.				
	in.	mm	in.	mm	in.	mm	in.	mm		in.	mm	in.	mm	in.	mm	in.	mm	in.	mm	in.	mm	in.	mm			
9100	0.52	13.2	0.47	11.9	0.95	24.1	0.91	23.1	200	0.56	14.2	0.50	12.7	0.98	24.9	0.97	24.6	300	0.59	15.0	0.50	12.7	1.18	30.0	1.15	29.2
9101	0.71	18.0	0.55	14.0	1.02	25.9	0.97	24.6	201	0.64	16.3	0.58	14.7	1.06	26.9	1.05	26.7	301	0.69	17.5	0.63	16.0	1.22	31.0	1.21	30.7
9102	0.75	19.0	0.67	17.0	1.18	30.0	1.13	28.7	202	0.75	19.0	0.69	17.5	1.18	30.0	1.15	29.2	302	0.81	20.6	0.75	19.0	1.42	36.1	1.40	35.6
9103	0.81	20.6	0.75	19.0	1.30	33.0	1.25	31.8	203	0.84	21.3	0.77	19.6	1.34	34.0	1.31	33.3	303	0.91	23.1	0.83	21.1	1.61	40.9	1.60	40.6
9104	0.98	24.9	0.89	22.6	1.46	37.1	1.41	35.8	204	1.00	25.4	0.94	23.9	1.61	40.9	1.58	40.1	304	1.06	26.9	0.94	23.9	1.77	45.0	1.75	44.4
9105	1.18	30.0	1.08	27.4	1.65	41.9	1.60	40.6	205	1.22	31.0	1.14	29.0	1.81	46.0	1.78	45.2	305	1.31	33.3	1.14	29.0	2.17	55.1	2.09	53.1
9106	1.38	35.1	1.34	34.0	1.93	49.0	1.88	47.8	206	1.47	37.3	1.34	34.0	2.21	56.1	2.16	54.9	306	1.56	39.6	1.34	34.0	2.56	65.0	2.44	62.0
9107	1.63	41.4	1.53	38.9	2.21	56.1	2.15	54.6	207	1.72	43.7	1.53	38.9	2.56	65.0	2.47	62.7	307	1.78	45.2	1.69	42.9	2.80	71.1	2.72	69.1
9108	1.81	46.0	1.73	43.9	2.44	62.0	2.39	60.7	208	1.94	49.3	1.73	43.9	2.87	72.9	2.78	70.6	308	2.00	50.8	1.93	49.0	3.19	81.0	3.06	77.7
9109	2.03	51.6	1.94	49.3	2.72	69.1	2.67	67.8	209	2.13	54.1	1.94	49.3	3.07	78.0	2.97	75.4	309	2.28	57.9	2.13	54.1	3.58	90.9	3.41	86.6
9110	2.22	56.4	2.13	54.1	2.91	73.9	2.86	72.6	210	2.34	59.4	2.13	54.1	3.27	83.1	3.17	80.5	310	2.50	63.5	2.36	59.9	3.94	100.1	3.75	95.2
9111	2.48	63.0	2.33	59.2	3.27	83.1	3.22	81.8	211	2.54	64.5	2.41	61.2	3.68	93.5	3.56	90.4	311	2.75	69.8	2.56	65.0	4.33	110.0	4.13	104.9
9112	2.67	67.8	2.53	64.3	3.47	88.1	3.42	86.9	212	2.81	71.4	2.67	67.8	3.98	101.1	3.87	98.3	312	2.94	74.7	2.84	72.1	4.65	118.1	4.44	112.8
9113	2.84	72.1	2.72	69.1	3.66	93.0	3.61	81.7	213	3.03	77.0	2.86	72.6	4.37	111.0	4.19	106.4	313	3.19	81.0	3.03	77.0	5.04	128.0	4.81	122.2
9114	3.11	79.0	2.91	73.9	4.06	103.1	3.97	100.8	214	3.22	81.8	3.06	77.7	4.57	116.1	4.41	112.0	314	3.44	87.4	3.23	82.0	5.43	137.9	5.13	130.3
9115	3.31	84.1	3.11	79.0	4.25	108.0	4.16	105.7	215	3.44	87.4	3.25	82.6	4.76	120.9	4.59	116.6	315	3.88	98.6	3.43	87.1	5.83	148.1	5.50	139.7
9116	3.56	90.4	3.31	84.1	4.65	118.1	4.50	114.3	216	3.69	93.7	3.55	90.2	5.12	130.0	4.93	125.2	316	3.94	100.1	3.62	91.9	6.22	158.0	5.88	149.4
9117	3.75	95.2	3.50	88.9	4.84	122.9	4.71	119.6	217	3.88	98.6	3.75	95.2	5.51	140.0	5.31	134.9	317	4.13	104.9	3.90	99.1	6.54	166.1	6.19	157.2
9118	4.03	102.4	3.84	97.5	5.16	131.1	5.13	130.3	218	4.16	105.7	3.94	100.1	5.91	150.1	5.62	142.7	318	4.38	111.3	4.09	103.9	6.93	176.0	6.50	165.1
9120	4.38	111.3	4.23	107.4	5.55	141.0	5.44	138.2	219	4.38	111.3	4.21	106.9	6.22	158.0	6.06	153.9	319	4.63	117.6	4.29	109.0	7.32	185.9	6.88	174.8
9121	4.66	118.4	4.53	115.1	5.91	150.1	5.75	146.0	220	4.63	117.6	4.41	112.0	6.61	167.9	6.31	160.3	320	4.88	124.0	4.49	114.0	7.91	200.9	7.38	187.4
9122	4.91	124.7	4.72	119.9	6.30	160.0	6.18	157.0	221	4.88	124.0	4.61	117.1	7.01	178.1	6.88	174.8	321	5.13	130.3	4.69	119.1	8.31	211.1	7.75	196.8
9124	5.28	134.1	5.12	130.0	6.69	169.9	6.50	165.1	222	5.13	130.3	4.80	121.9	7.40	188.0	7.06	179.3	322	5.50	139.7	4.88	124.0	8.90	226.1	8.25	209.6
9126	5.81	147.6	5.51	140.0	7.48	190.0	7.25	184.1	224	5.63	143.0	5.20	132.1	7.99	202.9	7.56	192.0	324	6.00	152.4	5.28	134.1	9.69	246.1	8.93	226.8
9128	6.06	153.9	5.81	147.6	7.88	200.2	7.68	195.1	226	6.00	152.4	5.67	144.0	8.50	215.9	8.13	206.5	326	6.44	163.6	5.83	148.1	10.32	262.1	9.69	246.1
9130	6.59	167.4	6.38	162.1	8.39	213.1	8.13	206.5	228	6.50	165.1	6.06	153.9	9.29	236.0	8.81	223.8	328	6.93	176.0	6.22	158.0	11.10	281.9	10.38	263.7
9132	6.96	176.8	6.56	166.6	9.00	228.6	8.75	222.2	230	6.97	177.0	6.46	164.1	10.08	256.0	9.50	241.3	330	7.44	189.0	6.61	167.9	11.89	302.0	11.06	280.9
9134	7.56	192.0	7.17	182.1	9.76	247.9	9.44	239.8	232	7.36	186.9	6.85	174.0	10.87	276.1	10.25	260.4	332	7.84	188.0	7.01	178.0	12.68	322.1	11.58	294.1
9138	8.38	212.9	7.95	201.9	10.95	278.1	10.50	266.7	234	7.98	202.7	7.40	188.0	11.50	292.1	10.88	276.4	334	8.40	213.4	7.40	188.0	13.47	342.1	12.27	311.7
9140	8.84	224.5	8.35	212.1	11.73	297.9	11.22	285.0	236	8.38	212.9	7.80	198.1	11.89	302.0	11.09	281.7	336	8.80	223.5	7.80	198.1	14.25	362.0	13.05	331.5
9144	9.70	246.4	9.21	233.9	12.84	326.1	12.24	310.9	238	8.77	222.8	8.19	208.0	12.68	322.1	11.88	301.8	338	9.35	237.5	8.35	212.1	14.89	378.2	13.59	345.2
9148	10.50	266.7	10.00	254.0	13.62	345.9	13.02	330.7	240	9.42	239.3	8.58	217.9	13.47	342.1	12.57	319.3	340	9.84	249.9	8.74	222.0	15.67	398.0	14.37	365.0
9152	11.49	291.8	10.95	278.1	15.04	382.0	14.44	366.8	242	9.69	246.1	8.87	225.3	14.26	362.2	13.26	336.8	342	10.24	260.1	9.14	232.2	16.47	418.3	15.17	385.3
9156	12.33	313.2	11.73	297.9	15.83	402.1	15.23	386.8	244	10.14	257.6	9.37	238.0	15.04	382.0	14.04	356.6	344	10.73	272.5	9.53	242.1	17.24	437.9	15.96	405.4
9160	13.36	339.3	12.52	318.0	17.40	442.0	16.60	421.6	246	10.58	268.7	9.76	247.9	15.83	402.1	14.60	370.8	348	11.52	292.6	10.32	262.1	18.82	478.0	17.32	439.9
9164	14.19	360.4	13.31	338.1	18.19	462.0	17.39	441.7	248	11.16	283.5	10.16	258.1	16.61	421.9	15.18	385.6	352	12.54	318.5	11.34	288.0	20.16	512.1	18.66	474.0
9180	18.00	457.2	17.00	431.8	22.12	561.8	21.62	549.1	250	11.55	293.4	10.55	268.0	17.40	442.0	15.70	398.8	356	13.43	341.1	12.13	308.1	21.73	551.9	20.13	511.3

FAFNIR RADIAL BALL BEARINGS

Basic Bearing Number	Heavy • 7400 Series			
	shaft, S		housing, H	
	max.	min.	max.	min.
	in. mm	in. mm	in. mm	in. mm
7405	1.47 37.3	1.34 34.0	2.80 71.1	2.63 66.8
7406	1.72 43.7	1.54 39.1	3.19 81.0	3.00 76.2
7407	1.93 49.0	1.73 43.9	3.58 90.9	3.38 85.9
7408	2.19 55.6	1.97 50.0	3.94 100.1	3.69 93.7
7409	2.44 62.0	2.17 55.1	4.33 110.0	4.00 101.6
7410	2.69 68.3	2.44 62.0	4.65 118.1	4.38 111.3

Basic Bearing Number	Heavy • 7400 Series (Continued)			
	shaft, S		housing, H	
	max.	min.	max.	min.
	in. mm	in. mm	in. mm	in. mm
7411	2.93 74.4	2.64 97.1	5.04 128.0	4.75 120.7
7412	3.19 81.0	2.84 72.1	5.43 137.9	5.13 130.3
7413	3.50 88.9	3.03 77.0	5.83 148.1	5.50 139.7
7414	3.69 93.7	3.31 84.1	6.54 166.1	6.13 155.7
7415	3.93 99.8	3.50 88.9	6.93 176.0	6.44 163.6
7416	4.13 104.9	3.70 94.0	7.32 185.9	6.81 173.0
7418	4.69 119.1	4.25 108.0	8.15 207.0	7.75 196.9
7420	5.17 131.3	4.72 119.9	9.21 233.9	8.79 223.3

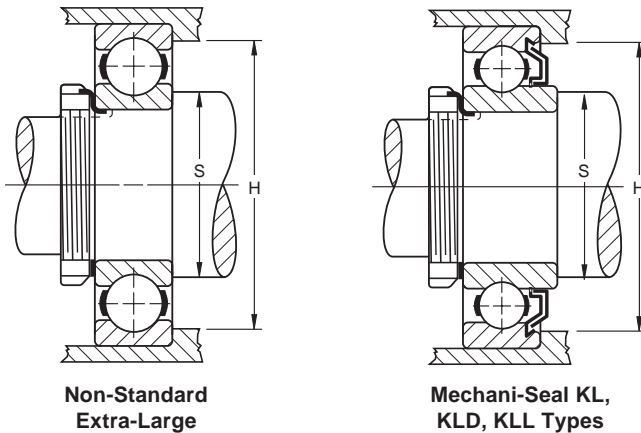

Housing shoulder diameters of bearings with Mechani-Seals differ slightly from those of other types to allow for clearance between the external rotating member of the seal and the housing shoulder.

Basic Bearing Number	Non-Standard Extra-Large							
	Shoulder Diameters							
	shaft, S				housing, H			
	max.		min.		max.		min.	
in.	mm	in.	mm	in.	mm	in.	mm	
120W2	4.63	117.6	4.40	111.8	5.91	150.1	5.75	146.0
122W	4.91	124.7	4.73	120.1	6.41	162.8	6.25	158.8
124W	5.28	134.1	5.12	130.0	7.01	178.1	6.87	174.5
126W	5.82	147.8	5.50	139.7	7.60	193.0	7.31	185.7
128W	6.19	157.2	5.91	150.1	8.18	207.8	7.96	202.2
130W	6.59	167.4	6.38	162.1	8.78	223.0	8.51	216.2
132W	7.44	189.0	6.85	174.0	9.24	234.7	8.81	223.8
134W	7.52	191.0	7.29	185.2	9.83	249.7	9.61	244.1
136W	8.00	203.2	7.69	195.3	10.42	264.7	10.15	257.8
138W	8.44	214.4	8.08	205.2	11.21	284.7	10.87	276.1
224W	5.63	143.0	5.20	132.1	8.00	203.2	7.56	192.0
226	6.00	152.4	5.67	144.0	8.50	215.9	8.13	206.5
228	6.50	165.1	6.06	153.9	9.29	236.0	8.81	223.8
276-2	15.82	401.8	15.75	400.1	18.25	463.6	18.17	461.5

Basic Bearing Number	Mechani-Seal KL, KLD, KLL Types			
	housing shoulder diameter, H			
	max.		min.	
	in.	mm	in.	mm
36	0.67	17.0	0.66	16.8
36V	0.67	17.0	0.66	16.8
37	0.79	20.1	0.77	19.6
37V	0.79	20.1	0.77	19.6
34	0.79	20.1	0.77	19.6
38V	0.79	20.1	0.77	19.6
39	0.91	23.1	0.89	22.6
39V	0.91	23.1	0.89	22.6
200	1.09	27.7	1.03	26.2
201	1.16	29.5	1.09	27.7
201-2	1.16	29.5	1.09	27.7
201-3	1.16	29.5	1.09	27.7
202	1.28	32.5	1.22	31.0
202-2	1.28	32.5	1.22	31.0
202-3	1.28	32.5	1.22	31.0
202-4	1.28	32.5	1.22	31.0
203	1.44	36.6	1.41	35.8
204	1.72	43.7	1.62	41.1
204-2	1.72	43.7	1.62	41.1
205	1.91	48.5	1.84	46.7
205-2	1.91	48.5	1.84	46.7
206	2.28	57.9	2.22	56.4
207	2.66	67.6	2.53	64.3
208	2.97	75.4	2.81	71.4
209	3.16	80.3	3.03	77.0
209-2	6.16	80.3	3.03	77.0
211	3.69	93.7	3.56	90.4

SHAFT AND HOUSING SHOULDERS

FAFNIR WIDE INNER RING BALL BEARINGS

When shafts are selected for use with wide inner ring bearings, a minimum slip fit is very desirable for the most satisfactory mounting. Special shaft limits are required in certain cases, and a variety of standard fits can be used, even including a press fit. The recommended figures are noted below. In some applications it may be permissible to use increased shaft tolerances. In such cases, applications should be forwarded to our The Timken Company for complete recommendations.

Bearing bore tolerance: $\frac{1}{2}'' - 2 \frac{3}{16}'' = \text{nominal to } +.0005, +.013\text{mm};$
 $2 \frac{1}{4}'' - 3 \frac{1}{16}'' = \text{nominal to } +.0006, +.015\text{mm};$
 $3 \frac{3}{16}'' - 1 \frac{15}{16}'' = \text{nominal to } +.0007, +.018\text{mm}$
 Recommended shaft tolerances: $\frac{1}{2}'' - 1 \frac{15}{16}'' = \text{nominal to } -.0005'', -.013\text{mm};$
 $2'' - 3 \frac{15}{16}'' = \text{nominal to } -.0010'', -.025\text{mm}.$

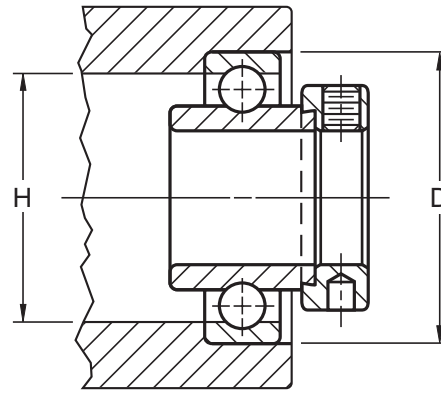

HOUSING, SHOULDERS AND SHAFT DIAMETERS

KRR Type	Bearing Number				Shaft Size	Basic Outer Ring Size	Housing Stationary ⁽¹⁾			Shoulder Diameter H	
	G-KRR Type	RA-RR Type	GRA-RR Type	GYA-RR* Type			Housing Bore, D min.	max	mean fit loose	max.	min.
					in. mm	in. mm	in. mm	in. mm	in. mm	in. mm	
1008KRR	-	RA008RR	GRA008RR	GYA008RR	$\frac{1}{2}$	203	1.5748 40.000	1.5754 40.015	0.0005 0.013	1.37 34.8	1.34 34.0
-	-	RA009RR	GRA009RR	GYA009RR	$\frac{9}{16}$						
1010KRR(KR)	G1010KRR	RA010RR	GRA010RR	GYA010RR	$\frac{5}{8}$						
1011KRR	G1011KRR	-	-	-	$1 \frac{1}{16}$						
E17KRR	GE17KRR	RAE17RR	GRAE17RR	GYAE17RR	17						
1012KRR(KR)	G1012KRR	RA012RR	GRA012RR	GYA012RR	$\frac{3}{4}$	204	1.8504 47.000	1.8510 47.015	0.0005 0.013	1.61 40.9	1.60 40.6
E20KRR	GE20KRR	RAE20RR	GRAE20RR	GYAE20RR	20						
1013KRR	-	RA013RR	GRA013RR	GYA013RR	$1 \frac{1}{16}$	205	2.0472 51.999	2.0479 52.017	0.0006 0.015	1.81 46.0	1.80 45.7
1014KRR	G1014KRR	RA014RR	GRA014RR	GYA014RR	$\frac{7}{8}$						
1015KRR(KR)	G1015KRR	RA015RR	GRA015RR	GYA015RR	$1 \frac{1}{8}$						
1100KRR(KR)	G1100KRR	RA100RR	GRA100RR	GYA100RR	1						
E25KRR	GE25KRR	RAE25RR	GRAE25RR	GYAE25RR	25						
-	G1101KRR	RA101RR	GRA101RR	GYA101RR	$1 \frac{1}{8}$	206	2.4409 61.999	2.4416 62.017	0.0006 0.015	2.21 56.1	2.16 54.9
1102KRR(KR)	G1102KRR	RA102RR	GRA102RR	GYA102RR	$1 \frac{1}{4}$						
1103KRR(KR)	G1103KRR	RA103RR	GRA103RR	GYA103RR	$1 \frac{3}{8}$						
-	-	-	-	GYA103RR2	$1 \frac{1}{2}$						
E30KRR	GE30KRR	RAE30RR	GRAE30RR	GYAE30RR	30						
1104KRR(KR)	G1104KRR	RA104RR	GRA104RR	GYA104RR	$1 \frac{3}{8}$	207	2.8346 71.999	2.8353 72.017	0.0006 0.015	2.21 56.1	2.16 54.9
1105KRR	-	RA105RR	GRA105RR	GYA105RR	$1 \frac{1}{2}$						
1106KRR	G1106KRR	RA106RR	GRA106RR	GYA106RR	$1 \frac{5}{8}$						
1107KRR(KR)	G1107KRR	RA107RR	GRA107RR	GYA107RR	$1 \frac{7}{8}$						
E35KRR	GE35KRR	RAE35RR	GRAE35RR	GYAE35RR	35						
1108KRR(KR)	G1108KRR	RA108RR	GRA108RR	GYA108RR	$1 \frac{1}{2}$	208	3.1496 80.000	3.1503 80.018	0.0006 0.015	2.87 72.9	2.78 70.6
-	-	RA106RR	GRA109RR	GYA109RR	$1 \frac{1}{8}$						
-	-	-	GRAE40RR	GYAE40RR	40						
1110KRR	G1110KRR	RA110RR	GRA110RR	GYA110RR	$1 \frac{3}{8}$	209	3.3465 85.001	3.3474 85.024	0.0008 0.020	3.07 78.0	2.97 75.4
1111KRR(KR)	G1111KRR	RA111RR	GRA111RR	GYA111RR	$1 \frac{1}{2}$						
1112KRR(KR)	G1112KRR	RA112RR	GRA112RR	GYA112RR	$1 \frac{3}{4}$						
E45KRR	-	-	GRAE45RR	GYAE45RR	45						
-	-	RA113RR	GRA113RR	GYA113RR	$1 \frac{5}{8}$						
1114KRR	-	RA114RR	GRA114RR	GYA114RR	$1 \frac{7}{8}$	210	3.5433 90.000	3.5442 90.023	0.0008 0.020	3.27 83.1	3.19 81.0
1115KRR(KR)	G1115KRR	RA115RR	GRA115RR	GYA115RR	$1 \frac{9}{16}$						
-	-	-	GRA115RR2	-	2						
E50KRR	GE50KRR	RAE50RR	GRAE50RR	GYAE50RR	50						
-	-	RA116RR	GRA116RR	GYA116RR	$1 \frac{1}{4}$						
1200KRR(KR)	G1200KRR	RA200RR	GRA200RR	GYA200RR	2	211	3.9370 100.000	3.9379 100.023	0.0008 0.020	3.58 90.9	3.56 90.4
-	-	RA201RR	GRA201RR	GYA201RR	$2 \frac{1}{16}$						
1202KRR	-	RA202RR	GRA202RR	GYA202RR	$2 \frac{1}{8}$						
1203KRR(KR)	G1203KRR	RA203RR	GRA203RR	GYA203RR	$2 \frac{1}{4}$						
E55KRR	GE55KRR	RAE55RR	GRAE55RR	GYAE55RR	55						
1204KRR	-	-	-	-	$2 \frac{3}{8}$	212	4.3307 110.000	4.3316 110.023	0.0008 0.020	3.98 101.1	3.87 98.3
1207KRR(KR)	G1207KRR	-	-	-	$2 \frac{1}{2}$						
E60KRR	GE60KRR	-	-	-	60						
1215KRR	-	-	-	-	$2 \frac{1}{2}$	215	5.1181 130.000	5.1191 130.025	0.0009 0.023	4.76 120.9	4.59 116.6
E75KRR	-	-	-	-	75						

⁽¹⁾ When the housing revolves in relation to the shaft, housing bore dimensions shown on page 33 should be used. Outer ring tolerances and housing fillet radii correspond to equivalent 200 Series single row radial bearings.

ISO BORE TOLERANCES-MILLIMETERS

Nominal Diameters		F7		G7		H8		N6		N7		R6		R7	
Over	Incl.	high	low	high	low	high	low	high	low	high	low	high	low	high	low
6	10	+0.028	+0.013	+0.020	+0.005	+0.022	0	-0.007	-0.016	-0.004	-0.019	-0.016	-0.025	-0.013	-0.028
10	18	+0.034	+0.016	+0.024	+0.006	+0.027	0	-0.009	-0.02	-0.005	-0.023	-0.020	-0.031	-0.016	-0.034
18	30	+0.041	+0.020	+0.028	+0.007	+0.033	0	-0.011	-0.024	-0.007	-0.028	-0.024	-0.037	-0.020	-0.041
30	50	+0.050	+0.025	+0.034	+0.009	+0.039	0	-0.012	-0.028	-0.008	-0.033	-0.029	-0.045	-0.025	-0.050
50	65	+0.060	+0.030	+0.040	+0.010	+0.046	0	-0.014	-0.033	-0.009	-0.039	-0.035	-0.054	-0.030	-0.060
65	80	+0.060	+0.030	+0.040	+0.010	+0.046	0	-0.014	-0.033	-0.009	-0.039	-0.037	-0.056	-0.032	-0.062
80	100	+0.071	+0.036	+0.047	+0.012	+0.054	0	-0.016	-0.038	-0.010	-0.045	-0.044	-0.066	-0.038	-0.073
100	120	+0.071	+0.036	+0.047	+0.012	+0.054	0	-0.016	-0.038	-0.010	-0.045	-0.047	-0.069	-0.041	-0.076
120	140	+0.083	+0.043	+0.054	+0.014	+0.063	0	-0.020	-0.045	-0.012	-0.052	-0.056	-0.081	-0.048	-0.088
140	160	+0.083	+0.043	+0.054	+0.014	+0.063	0	-0.020	-0.045	-0.012	-0.052	-0.058	-0.083	-0.050	-0.090
160	180	+0.083	+0.043	+0.054	+0.014	+0.063	0	-0.020	-0.045	-0.012	-0.052	-0.061	-0.086	-0.053	-0.093
180	200	+0.096	+0.050	+0.061	+0.015	+0.072	0	-0.022	-0.051	-0.014	-0.060	-0.068	-0.097	-0.060	-0.106
200	225	+0.096	+0.050	+0.061	+0.015	+0.072	0	-0.022	-0.051	-0.014	-0.060	-0.071	-0.100	-0.063	-0.109
225	250	+0.096	+0.050	+0.061	+0.015	+0.072	0	-0.022	-0.051	-0.014	-0.060	-0.075	-0.104	-0.067	-0.113

ISO SHAFT TOLERANCES-MILLIMETERS

Nominal Diameters		f5		f6		h5		h6		j6		m6	
Over	Incl.	high	low	high	low	high	low	high	low	high	low	high	low
3	6	-0.010	-0.015	-0.010	-0.018	0	-0.005	0	-0.008	+0.006	-0.002	+0.012	+0.004
6	10	-0.013	-0.019	-0.013	-0.022	0	-0.006	0	-0.009	+0.007	-0.002	+0.015	+0.006
10	18	-0.016	-0.024	-0.016	-0.027	0	-0.008	0	-0.011	+0.008	-0.003	+0.018	+0.007
18	30	-0.020	-0.029	-0.020	-0.033	0	-0.009	0	-0.013	+0.009	-0.004	+0.021	+0.008
30	50	-0.025	-0.036	-0.025	-0.041	0	-0.011	0	-0.016	+0.011	-0.005	+0.025	+0.009
50	80	-0.030	-0.043	-0.030	-0.049	0	-0.013	0	-0.019	+0.012	-0.007	+0.030	+0.011
80	120	-0.036	-0.051	-0.036	-0.058	0	-0.015	0	-0.022	+0.013	-0.009	+0.035	+0.013
120	180	-0.043	-0.061	-0.043	-0.068	0	-0.018	0	-0.025	+0.014	-0.011	+0.040	+0.015

ISO BORE TOLERANCES - INCH

Nominal Diameters		F7		G7		H8		N6		N7		R6		R7	
Over	Incl.	high	low	high	low	high	low	high	low	high	low	high	low	high	low
0.2362	0.3937	+0.0011	+0.0005	+0.0008	+0.0002	+0.0009	0	-0.0003	-0.0006	-0.0002	-0.0007	-0.0006	-0.001	-0.0005	-0.0011
0.3937	0.7087	+0.0013	+0.0006	+0.0009	+0.0002	+0.0011	0	-0.0004	-0.0008	-0.0002	-0.0009	-0.0008	-0.0012	-0.0006	-0.0013
0.7087	1.1811	+0.0016	+0.0008	+0.0011	+0.0003	+0.0013	0	-0.0004	-0.0009	-0.0003	-0.0011	-0.0009	-0.0015	-0.0008	-0.0016
1.1811	1.9685	+0.0020	+0.0010	+0.0013	+0.0004	+0.0015	0	-0.0005	-0.0011	-0.0003	-0.0013	-0.0012	-0.0018	-0.001	-0.002
1.9685	2.5591	+0.0024	+0.0012	+0.0016	+0.0004	+0.0018	0	-0.0006	-0.0013	-0.0004	-0.0015	-0.0014	-0.0021	-0.0012	-0.0024
2.5591	3.1496	+0.0024	+0.0012	+0.0016	+0.0004	+0.0018	0	-0.0006	-0.0013	-0.0004	-0.0015	-0.0015	-0.0022	-0.0013	-0.0024
3.1496	3.9370	+0.0028	+0.0014	+0.0018	+0.0005	+0.0021	0	-0.0006	-0.0015	-0.0004	-0.0018	-0.0017	-0.0026	-0.0015	-0.0029
3.9370	4.7244	+0.0028	+0.0014	+0.0018	+0.0005	+0.0021	0	-0.0006	-0.0015	-0.0004	-0.0018	-0.0018	-0.0027	-0.0016	-0.003
4.7244	5.5118	+0.0033	+0.0017	+0.0021	+0.0006	+0.0025	0	-0.0008	-0.0018	-0.0005	-0.002	-0.0022	-0.0032	-0.0019	-0.0035
5.5118	6.2992	+0.0033	+0.0017	+0.0021	+0.0006	+0.0025	0	-0.0008	-0.0018	-0.0005	-0.002	-0.0023	-0.0033	-0.002	-0.0035
6.2992	7.0866	+0.0033	+0.0017	+0.0021	+0.0006	+0.0025	0	-0.0008	-0.0018	-0.0005	-0.002	-0.0024	-0.0034	-0.0021	-0.0037
7.0866	7.8740	+0.0038	+0.0020	+0.0024	+0.0006	+0.0028	0	-0.0009	-0.002	-0.0006	-0.0024	-0.0027	-0.0038	-0.0024	-0.0042
7.8740	8.8583	+0.0038	+0.0020	+0.0024	+0.0006	+0.0028	0	-0.0009	-0.002	-0.0006	-0.0024	-0.0028	-0.0039	-0.0025	-0.0043
8.8583	9.8425	+0.0038	+0.0020	+0.0024	+0.0006	+0.0028	0	-0.0009	-0.002	-0.0006	-0.0024	-0.003	-0.0041	-0.0026	-0.0044

ISO SHAFT TOLERANCES - INCH

Nominal Diameters		f5		f6		h5		h6		j6		m6	
Over	Incl.	high	low	high	low	high	low	high	low	high	low	high	low
0.1181	0.2362	-0.0004	-0.0006	-0.0004	-0.0007	0	-0.0002	0	-0.0003	+0.0002	-0.0001	+0.0005	+0.0002
0.2362	0.3937	-0.0005	-0.0007	-0.0005	-0.0009	0	-0.0002	0	-0.0004	+0.0003	-0.0001	+0.0006	+0.0002
0.3937	0.7087	-0.0006	-0.0009	-0.0006	-0.0011	0	-0.0003	0	-0.0004	+0.0003	-0.0001	+0.0007	+0.0003
0.7087	1.1811	-0.0008	-0.0011	-0.0008	-0.0013	0	-0.0004	0	-0.0005	+0.0004	-0.0002	+0.0008	+0.0003
1.1811	1.9685	-0.001	-0.0014	-0.001	-0.0016	0	-0.0004	0	-0.0006	+0.0004	-0.0002	+0.0010	+0.0004
1.9685	3.1496	-0.0012	-0.0017	-0.0012	-0.0019	0	-0.0005	0	-0.0007	+0.0004	-0.0003	+0.0012	+0.0004
3.1496	4.7244	-0.0014	-0.002	-0.0014	-0.0023	0	-0.0006	0	-0.0009	+0.0005	-0.0004	+0.0014	+0.0005
4.7244	7.0866	-0.0017	-0.0024	-0.0017	-0.0027	0	-0.0007	0	-0.0010	+0.0006	-0.0004	+0.0016	+0.0006

HYDRAULIC NUTS

INTRODUCTION

Timken® Torrington® hydraulic nuts have been designed to install and remove tapered bore bearings with minimal effort. The use of hydraulic nuts allows for better control of the bearing internal clearance reduction without damaging the bearing or other components. Also, the hydraulic nut will considerably reduce the downtime during installation or removal of tapered bore bearings.

DESCRIPTION

The Torrington hydraulic nut consists of an internally threaded ring and an externally threaded ring with two o-ring seals.

All hydraulic nuts are supplied with:

- Quick connection fittings (external thread 1/4" B.S.P. and internal thread 3/8" N.P.T.)
- Two pipe plugs 1/4" B.S.P.
- One set of spare o-rings.

INSTRUCTIONS

When the hydraulic nut is used, the piston must be in the innermost position. For this operation, please ensure that the valve of the hydraulic hose is disconnected from the nut so that the nut is not under pressure.

To contract the piston inside the internally threaded ring, insert a rod bar in one of the four drilled holes located on the outside diameter of the internally threaded ring. Screw the hydraulic nut on the thread with the piston in contact with the surface until the groove machined on the outside diameter of the piston near the outboard face is level with the face of the internally threaded ring.

One of the two threaded holes must be plugged with the 1/4" B.S.P. pipe plug before the hydraulic nut is pressurized. The maximum pressure permissible in the hydraulic nut is 14,000 psi (100 Kpa). The oil viscosity recommended is 1,400 SUS (300 cst) at operating temperature, (SAE 90 oil). To avoid over extension of the piston, a second groove has been machined on the outside diameter of the piston inboard of the one used to judge contraction. When this second groove is level with the face of the internally threaded ring, the piston has reached its length of travel as shown on the tables. If the second groove of the piston travels past the face of the internally threaded ring, the piston will not be correctly guided inside the threaded ring and the hydraulic nut can be damaged.

Should the oil start to leak from the piston area, it is certain that the o-ring seals are damaged or worn and need to be replaced.

When the hydraulic nut is not in use, ensure that the threaded holes are plugged to prevent the entry of contaminants in the piston cavity. To preserve against corrosion during storage, apply a coat of light oil on the hydraulic nut surfaces.

ORDERING COMPONENTS

Contact your local Timken Sales office or nearest authorized Timken bearing distributor for ordering Torrington hydraulic nut systems.

ENGINEERING SERVICES

Special applications should be referred to a Timken Sales Engineer for recommendations.

Installation

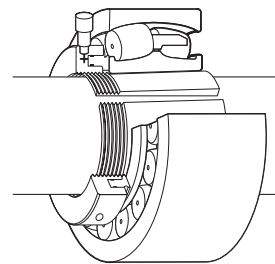

Hydraulic nut used to mount the bearing on a pull type sleeve.

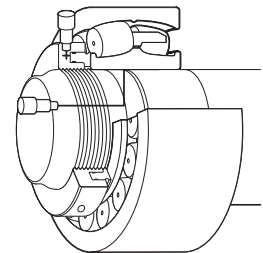

Hydraulic nut used to mount the bearing on tapered journal.

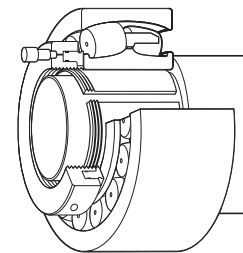

Hydraulic nut used to mount the bearing on a push type adapter sleeve.

Removal

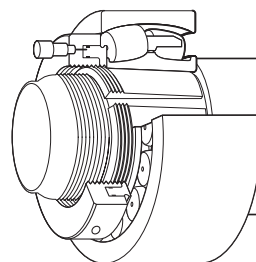

Hydraulic nut used to withdraw a push type adapter sleeve.



**For your nearest Timken sales representative, call (800) 223-1954.
Outside the U.S. and Canada, call (330) 438-3000.**

Timken[®], Torrington[®], and Fafnir[®] are registered trademarks
of The Timken Company.
www.timken.com

©2003 by The Timken Company
Printed in U.S.A.
5M-10-03-8 Order No. 5734 (formerly Torrington No. 638)

TIMKEN

WORLDWIDE LEADER IN BEARINGS AND STEEL